

Stripper Spring Assemblies

Stripping Spring Assemblies

Recommended Use; 75% or Less of Available Travel

- [Stripping Spring Assemblies - Coil Spring Series](#)
- [Spare Springs](#)

COIL SPRING SERIES Medium Pressure

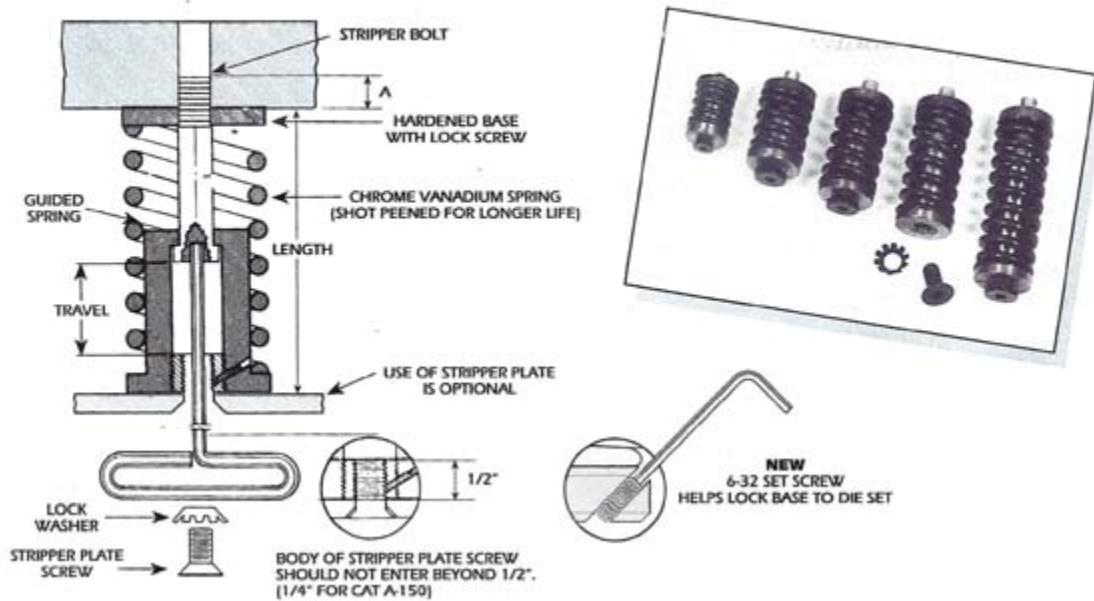

[Coil Spring Series](#)

Catalog No.	Length	Outside Diameter	Thread Length	Stripper Bolt & Stripper Plate Screw Size	Hex Wrench Size for Stripper Bolt	Travel	Load Lbs. Per 1/10' Deflection	Pre-Load Lbs.	Max Load Lbs.	Shipping Weight Each
A-150	1-1/2"	1"	.250	1/4-20	5/32	5/16	37	85	200	4 oz.
A-200	2"	1-5/16"	.500	3/8-24	3/16	7/16	80	294	644	9 oz.
A-250	2-1/2"	1-5/16"	.500	3/8-24	3/16	9/16	60	280	617	10 oz.
A-300	3"	1-5/16"	.500	3/8-24	3/16	13/16	47	220	600	11 oz.
A-400	4"	1-5/16"	.500	3/8-24	3/16	1-1/16	32	150	490	13 oz.

The coil spring assemblies are designed for medium pressure applications in blanking, piercing and forming dies-plus many other uses. Simply, drill and tap 3/8" - 24 location holes for each assembly. (1/4" - 20 tap for catalog A-150). The assemblies can be used with or without a stripper plate if the design is suitable. A 3/8" - 24 x 3/4" LG. FLAT HEAD SCREW WITH LOCK WASHER IS FURNISHED FOR RETAINING A 1/4" THICK STRIPPERPLATE. (1/4" - 20 X 112" SCREW FOR CAT. A-150 ONLY.)

[Spare Springs](#)

Catalog No.	Description
A-151	Spring for A-150
A-201	Spring for A-200
A-251	Spring for A-250
A-301	Spring for A-300
A-401	Spring for A-400

CLARK & OSBORNE

If a stripper plate is used, caution must be used to make sure the screw does not enter the travel area as shown in the above drawing. Cap screws may be used for holding the stripper plate, however, this would require a much thicker plate to accommodate the thicker head on the screw. Some users save additional time and money by only attaching a portion of the assemblies to the stripper plate, provided the design is suitable.