

Ultra quiet ball screw **F series**

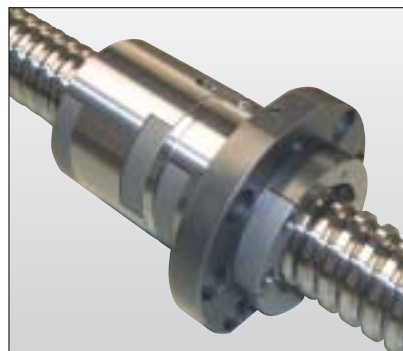

Please Order From:
Clark & Osborne, LLP
6617 Ferguson Avenue
Indianapolis, IN 46220

Phone: (317) 255-5668
Fax: (317) 253-4486
sales@ClarkAndOsborne.com
www.ClarkAndOsborne.com



Based on proven-precise gauge grinding technology
 Ideal for semiconductor, machine tool, SMT,
 medical lab application and more

FEATURES

Ultra-Quiet F Series ball screw delivers higher rotational speed, lower sound pressure level, more compact size, and longer life without compromising load capacity, ball diameter and other features of the previous model.

CONSTRUCTION

The ball circulation mechanism of the F Series ball screw is designed to facilitate the flow of steel balls with a newly introduced end-deflector. This provides higher rotational speed and quieter operation, along with compact nut.

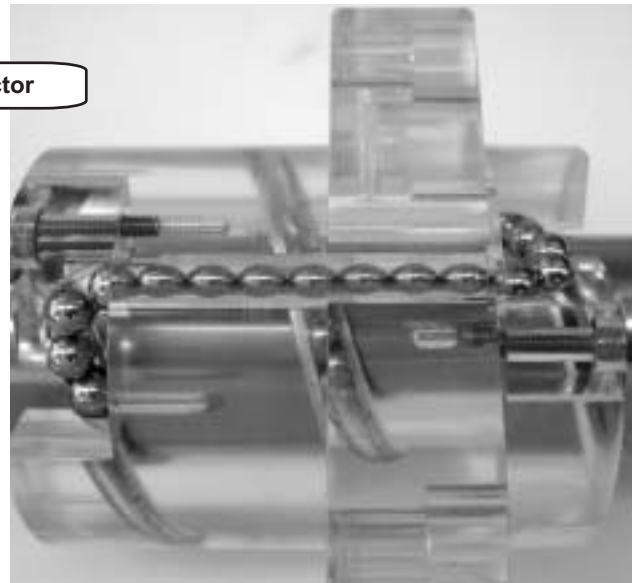
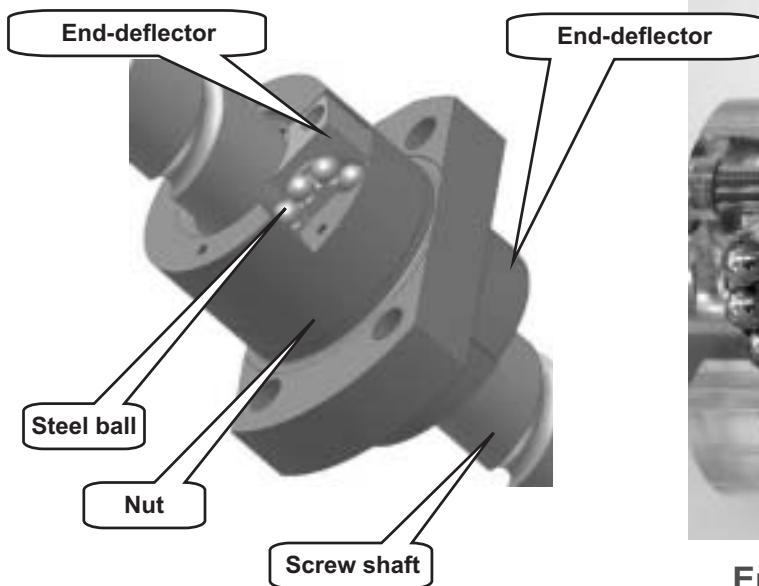

End-deflector method circulation

SERIES

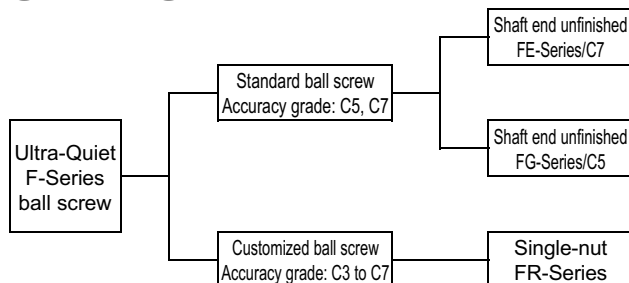

● Combinations of screw shaft and lead

Screw shaft diameter (mm)	Lead(mm)						
	5	8	10	12	16	20	25
15	● □		● □			● □	
20			● □			● □	
25	● □		● □				● □
32	□	□ *		□ *	□ *		
36				□ *	□ *		
40		□ *	□ *	□ *	□ *		

●:Standard ball screw (single-nut) FE (C7) /FG (C5)

□:Customized ball screw (single-nut) (C3 to C7)

*:Sizes of the customized ball screws for which the double-nut is available

(Note 1)

(Note 1) For the customized ball screws for which the double-nut is available, see the reference specifications on Page 27 of this catalogue. The specifications of a ball screw with the double-nut will be determined through consultation. Please complete the datasheet of ball screw specifications on Page 29 beforehand, and contact KURODA.

Ultra-Quiet ball screw/F Series

LOWER SOUND PRESSURE AND LESS HARSH NOISE

The F Series ball screw delivers up to 6dB lower sound pressure as well as less harsh noise in the higher frequency range above 5000Hz, compared to the previous model (tube circuit method).

● Quieter Operation

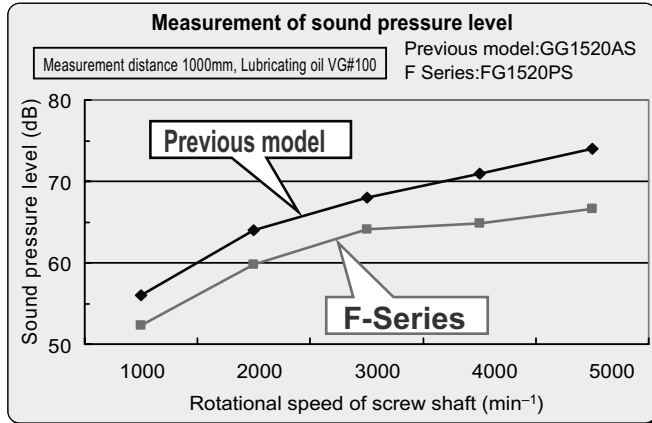

● Less Harsh Noise

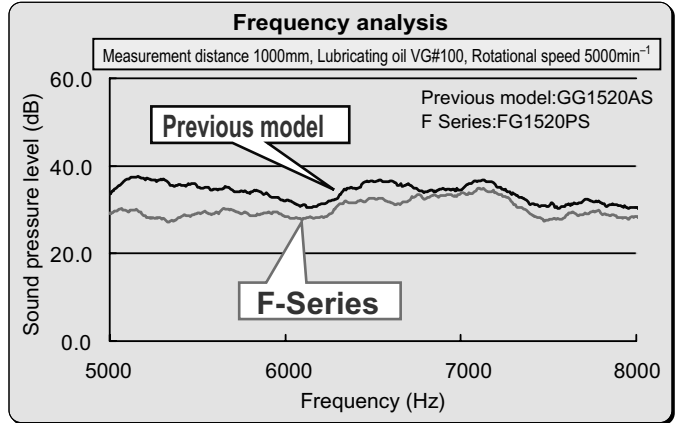

HIGHER ROTATIONAL SPEED

For the previous model of ball screw, the rotational speed of the balls circulated in the nut is limited to 70,000 in DmN* value.
*DmN = Dm (ball pitch circle dia. in mm) X N (max. rotational speed in min⁻¹)

The F Series ball screw is designed to facilitate the circulation of balls inside the nut. This allows the ball screw to attain a remarkably higher maximum rotational speed than the previous model. The following table compares the tables' rotational speeds between the ball screws of F Series and the previous model.

● Comparison of the table speeds between the ball screws of F-Series and the previous model (tube method)

Screw shaft dia. (mm)	Values compared	Unit	Lead(mm)													
			5		8		10		12		16		20		25	
			F-Series	Previous model	F-Series	Previous model	F-Series	Previous model	F-Series	Previous model	F-Series	Previous model	F-Series	Previous model	F-Series	Previous model
15	R.S.	min ⁻¹	5,000	4,430			5,000	4,430					5,000	4,430		
	T.S.	mm/s	417	369			833	738					1,667	1,477		
20	R.S.	min ⁻¹					5,000	3,333					5,000	3,349		
	T.S.	mm/s					833	556					1,667	1,116		
25	R.S.	min ⁻¹	5,000	2,713			5,000	2,692							5,000	2,692
	T.S.	mm/s	417	226			833	449							2,083	1,122
32	R.S.	min ⁻¹	4,000	2,134	4,000	2,121			4,000	2,071	4,000	2,071				
	T.S.	mm/s	333	178	533	283			800	414	1,067	552				
36	R.S.	min ⁻¹							3,500	1,842	3,500	1,842				
	T.S.	mm/s							700	368	933	491				
40	R.S.	min ⁻¹			3,200	1,707	3,200	1,675	3,200	1,667	3,200	1,667				
	T.S.	mm/s			427	228	533	279	640	333	853	444				

R.S.:Rotational speed T.S.:Table speed

(Note) The rotational speeds and table speeds in the above list are calculated from DmN. The actual permissible rotational speed (or permissible table speed) must be determined while taking into consideration of its critical speed that is dependent on the screw shaft length.

Ultra-Quiet ball screw/F Series

COMPACTIFICATION

The F Series ball screw is designed to introduce an original ball circuit by installing the ball circuit parts on both end of the nut, making the overall length of the nut shorter and the outer diameter of the screw body smaller. The following table compares the nut dimensions between the ball screws of F Series and the previous model.

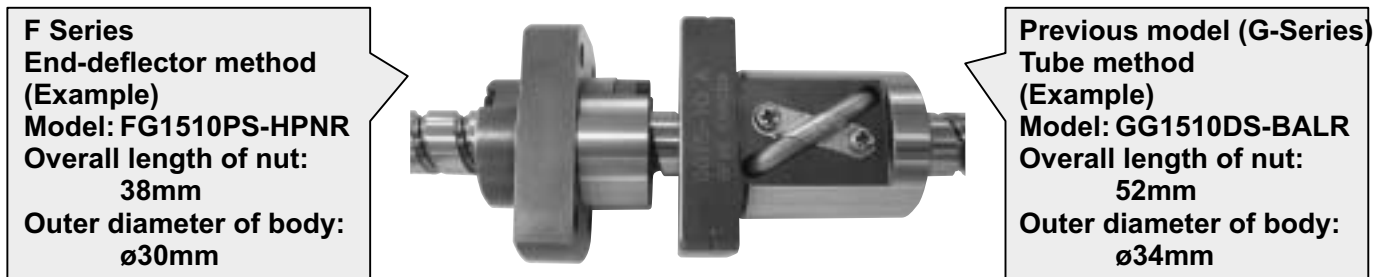

● Comparison of the nut dimensions between the ball screws of F Series and the previous model (tube method)

Screw shaft dia. (mm)	Values compared	Unit	Lead(mm)													
			5		8		10		12		16		20		25	
			F Series	Previous model	F Series	Previous model	F Series	Previous model	F Series	Previous model	F Series	Previous model	F Series	Previous model	F Series	Previous model
15	N.O.C.	—	2.7X1	2.5X1			2.7X1	2.5X1					1.7X1	1.5X1		
	N.O.L.	mm	25	44			38	52					48	62		
	N.B.D.		30	34			30	34					30	34		
20	N.O.C.	—					2.7X1	2.5X1					1.7X1	1.5X1		
	N.O.L.	mm					38	65					48	70		
	N.B.D.						40	46					40	46		
25	N.O.C.	—	3.7X1	3.5X1			2.7X1	2.5X1							1.7X1	1.5X1
	N.O.L.	mm	30	53			37	65							58	77
	N.B.D.		40	47			45	52							45	54
32	N.O.C.	—	3.7X1	3.5X1	3.7X1	3.5X1			3.7X1	3.5X1	3.7X1	3.5X1				
	N.O.L.	mm	30	48	42	73			65	93	78	96				
	N.B.D.		52	58	56	66			62	74	62	74				
36	N.O.C.	—							3.7X1	3.5X1	3.7X1	3.5X1				
	N.O.L.	mm							62	93	80	96				
	N.B.D.								70	81	70	81				
40	N.O.C.	—			3.7X1	3.5X1	3.7X1	3.5X1	3.7X1	3.5X1	3.7X1	3.5X1				
	N.O.L.	mm			44	65	55	91	63	93	78	107				
	N.B.D.				64	74	70	82	74	86	74	86				

N.O.C.:Number of circuits N.O.L.:Nut overall length N.B.D.:Nut body diameter

LONGER LIFE

The F Series ball screw is designed to meet the requirements on specifications without changing the ball diameter from the previous model, delivering a better basic dynamic/static load rating. The following list compares the load capacities between the ball screws of F Series and the previous model.

● Comparison of the load capacities between the ball screws of F Series and the previous model (tube method)

Screw shaft dia. (mm)	Values compared	Unit	Lead(mm)													
			5		8		10		12		16		20		25	
			F Series	Previous model	F Series	Previous model	F Series	Previous model	F Series	Previous model	F Series	Previous model	F Series	Previous model	F Series	Previous model
15	B.D.L.R.	N	7,400	6,900			7,400	6,900					4,800	4,400		
	B.S.L.R.	N	12,900	12,500			12,900	12,500					8,200	7,900		
20	B.D.L.R.	N					18,000	13,500					11,600	9,200		
	B.S.L.R.	N					33,900	25,100					20,600	16,200		
25	B.D.L.R.	N	13,100	12,500			20,400	16,100							13,100	10,400
	B.S.L.R.	N	31,800	31,080			42,600	33,400							25,900	20,100
32	B.D.L.R.	N	14,700	14,000	30,100	23,700			43,100	34,500	43,100	34,500				
	B.S.L.R.	N	41,600	40,000	74,600	58,380			97,000	77,800	97,000	77,800				
36	B.D.L.R.	N							59,500	43,700	59,500	43,700				
	B.S.L.R.	N							140,500	97,600	140,500	97,600				
40	B.D.L.R.	N			34,400	26,100	49,400	39,100	64,000	46,800	64,000	46,800				
	B.S.L.R.	N			98,300	75,800	125,800	104,000	160,700	110,600	160,700	110,600				

B.D.L.R.:Basic dynamic load rating B.S.L.R.:Basic static load rating

Ultra-Quiet ball screw/F Series

OPTIONS

The following table shows the options available for the F Series ball screws.

Series	End machining	Axial clearance adjustment	Surface treatment(Note 1)	Difference of grease	Direction of nut	LUBSEAL installation
FE	○	×	○	○	○	○
FG	○	○(Note 2)	○	○	○	○
FR	(Note 3)	(Note 4)	○	○	(Note 5)	○

(Note 1) Anticorrosive black coating (coating thickness: 1 to 2μm).

(Note 2) For axial clearance adjustment in the FG Series ball screw, please contact KURODA.

(Note 3) The FR Series ball screw is manufactured by order basis. The shape of the screw shaft end can be customized.

(Note 4) The axial clearance of the FR Series ball screw can be selected from 0mm (preloaded), 0.005mm, 0.010mm, or 0.030mm, according to the specifications.

(Note 5) For the FR Series ball screw, the direction of the nut is specified by customer's drawing.

LUBSEAL[®] (LUBRICATION UNIT)



● Notation of Model Number

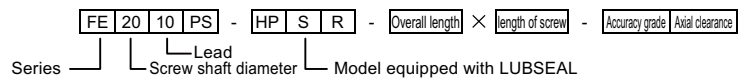

Screw shaft diameter (mm)	Lead (mm)	Model number of ball screw with LUBSEAL
15	5	FE/FG/FR1505PS-HPSR-
	10	FE/FG/FR1510PS-HPSR-
	20	FE/FG/FR1520PS-HPSR-
20	10	FE/FG/FR2010PS-HPSR-
	20	FE/FG/FR2020PS-HPSR-
25	5	FE/FG/FR2505PS-HPSR-
	10	FE/FG/FR2510PS-HPSR-
	25	FE/FG/FR2525PS-HPSR-
32	5	FR3205PS-DPSR-
	8	FR3208PS-DPSR-
	12	FR3212PS-DPSR-
	16	FR3216PS-DPSR-
36	12	FR3612PS-DPSR-
	16	FR3616PS-DPSR-
40	8	FR4008PS-DPSR-
	10	FR4010PS-DPSR-
	12	FR4012PS-DPSR-
	16	FR4016PS-DPSR-

● Construction

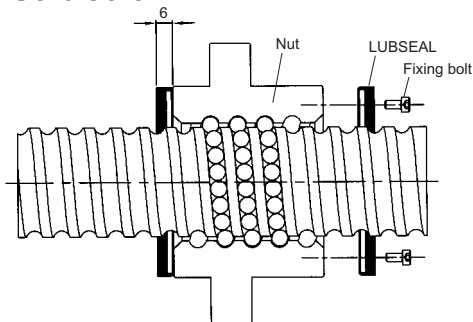

※After LUBSEAL is installed into the F Series nut, the overall length of the nut will be 12mm longer (6 mm longer on each side).

The head of a fixing bolt does not protrude from LUBSEAL.

※For other shaft diameter and/or leads, consult KURODA.

The ends of a ball screw can be finished in our factory.

※The photo at the upper-left shows LUBSEAL of which surface is painted to distinguish it from the ball screw. LUBSEAL itself is made of stainless steel, and its surface is not painted.



Operating Cautions

- Do not use an organic solvent.
Using an organic solvent can cause malfunction.
- Do not use LUBSEAL at a temperature exceeding the upper limit of the operating temperature. Using LUBSEAL at a temperature of above 50°C can cause malfunction.
- Temperature rise during operation
As LUBSEAL touches the screw shaft, heat is produced during operation. Positioning accuracy may change by expansion of shaft as temperature rises. How much LUBSEAL will see a rise in the temperature varies depending the operating conditions.

- Do not overrun LUBSEAL.
As LUBSEAL touches the screw shaft, do not overrun it; otherwise causing troubles.
- Driving torque
As LUBSEAL touches the screw shaft, sliding torque is caused.
The self-weight drop test cannot be performed in the acceptance inspection of a customer.
- Do not mix different kinds of grease.
Mixing different kinds of grease can damage the functionality of LUBSEAL.

Ultra-Quiet ball screw/F Series

NOTATION OF MODEL NUMBER

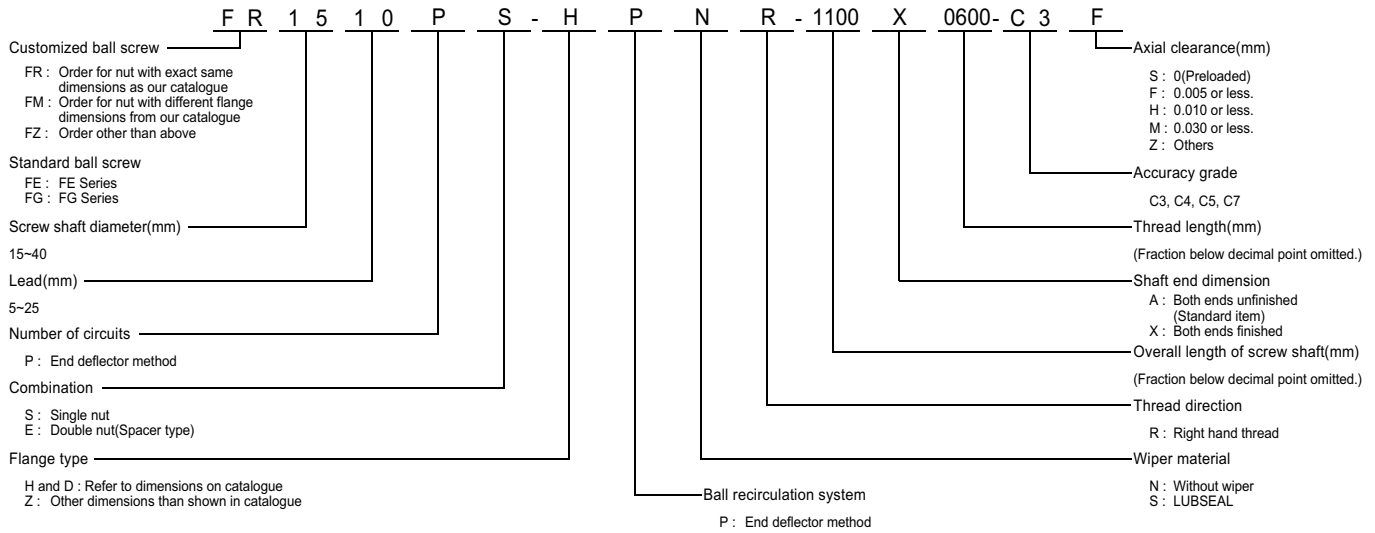

Shaft ends unfinished ball screw

FE/FG Series Ball Screw

Ordering example for model without additional machining

(Ordering Example) **FE** - - Overall length **A**
FG - - Overall length **A**

Basic model number

Ordering example for model without additional machining

Use symbol X to show the necessity of end machining, and fill overall length of screw shaft, thread length and axial clearance.

(Ordering Example) **FE** - - Overall length **X** - **C7M**
FG - - Overall length **X** - **C5F**

Order for nut with exact same dimensions as our catalogue

In this case, fill overall length of screw shaft, thread length, accuracy and axial clearance after model number, without changing model number.

(Ordering Example) **FR** - - Overall length **X** -

Basic model number

Order for nut with different flange dimensions from our catalogue

In this case, use symbol FM at head of model number and use symbol Z to show flange type. Enter overall length of screw shaft, thread length, accuracy and axial clearance after model number.

(Ordering Example) **FM** - **Z** - Overall length **X** -

Basic model number

Order other than above such as different nut construction and different size from our catalogue

In this case, use symbol FZ at head of model number. Change necessary place and then fill overall length of screw shaft, thread length, accuracy and axial clearance after model number.

(Ordering Example) **FZ** - **Z** - Overall length **X** -

Basic model number

CONTENTS

Ultra-quiet ball screw(Features, Series)	1	Ball Screw/Common Instructions	7
Ultra-quiet ball screw(Sound pressure, High rotational speed)	2	FE/FG Series Dimensions and Shaft end finish ordering sheet	9
Ultra-quiet ball screw(Compactification, Longer life)	3	FR Series Dimensions	25
Options	4	Customized ball screw with double nut	27
Notation of model number	5	Ball screw ordering information	29
For Safety Use	6		



FOR SAFETY USE



Be sure to read the following instructions before use.

For common and individual instructions, refer to the text of this catalogue.

The following safety precautions are provided to prevent damage and danger to personnel and to provide instructions on the correct usage of this product.

These precautions are classified into 3 categories: "DANGER", "WARNING" and "CAUTION" according to the degree of possible injury or damage and the degree of impendence of such injury or damage.

Be sure to follow all these precautions, as they include important contents regarding safety.

 DANGER	 WARNING	 CAUTION
Indicates an impending hazardous situation which may arise due to improper handling or operation and could result in serious personal injury or death.	Indicates a potentially hazardous situation which may arise due to improper handling or operation and could result in serious personal injury or death.	Indicates a potentially hazardous situation which may arise due to improper handling or operation and could result in personal injury or property-damage-only accidents.

Be sure to obey the "Labor Safety and Sanitation Law" and other safety rules and regulations in addition to these precautions.

There is some situation that may lead to a serious result according to circumstances, even if it is mentioned in the category of "CAUTION".

Be sure to follow these precautions, as they contain important matters.

WARNING

●Select a ball screw properly.

Products placed here are used in various operating conditions. Therefore, a total system designer or a responsible person for determining specifications must determine that the product conforms to the system after conducting analysis and tests as required.

The person who determines that the product conforms to the system must be responsible for the expected performance of such a system and the assurance of safety.

When configuring a system, thoroughly examine the complete contents of specifications by referring to the latest product catalogue and data, and take into consideration the possibility of equipment troubles and the situation of such troubles.

●A person with sufficient knowledge and experience must handle the product.

- Thoroughly read this catalogue and operation manual before use.
- Never disassemble the ball screw. Dust may enter, thus degrading accuracy and causing an accident.
If the product has been disassembled for some reason, return it to our company. It will be repaired or reassembled (Repair cost is charged.)
- When mounting/dismounting a ball screw to a machine, check that an appropriate drop prevention measures is provided and the moving part of the machine is fixed beforehand.

●Products placed here are mainly used for general industrial machinery.

When using them in the following conditions and environments, take safety measures and consult with our company beforehand.

- Use in conditions and environments other than the given specifications and out of doors.
- Use for atomic energy, railroads, airplanes, vehicles, ships, medical equipment, and equipment that contacts drink and food.
- Use for applications where a great influence on the human body and property is anticipated, and where special safety is required.



BALL SCREW/COMMON INSTRUCTIONS ①

Be sure to read the following instructions before use.
Also refer to "FOR SAFETY USE".

PRECAUTIONS FOR DESIGN

WARNING

- Number of revolutions
Refer to the permissible number of revolutions shown on this catalogue and use at the permissible number of revolutions or lower.
If it is used over the given DmN value, the circulating parts will be damaged, making operation impossible. In the case of vertical shaft, the ball may come off, sometimes dropping the head etc. or resulting in other accident.

CAUTION

- Dustproof cover
When intrusion of dust or foreign matters is presupposed, provide the ball screw with a dust guard such as bellows and telescopic cover.
To make it more effective, provide a wiper on both ends of the nut.
If dust or foreign matters get into the nut of a ball screw, defective operation, abnormal sound, abnormal vibration, early wear-out, early fraking and other various troubles will be caused.

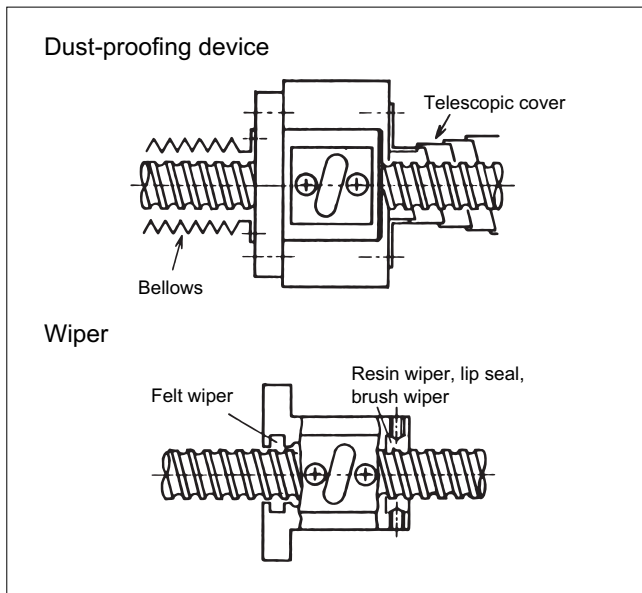

- Unbalanced load
In designing a system, take care that radial load and moment load may not be directly applied to the ball screw.
Otherwise, part of the balls will suffer heavy load, thus shortening the service life of the ball screw.
- Precautions for mounting a ball screw
For easy mounting a ball screw to a machine/device, design that it can be mounted with the nut fitted to the screw shaft.
If the nut is removed, the balls will come out from the ball circuit, thus breaking the recirculation parts.
When it is inevitable to remove the nut, consult KURODA beforehand.

PRECAUTIONS FOR OPERATION AND MOUNTING

WARNING

- Avoid overrun.
If the nut of a ball screw is overrun and shocked at the stroke end, an indentation will occur in the thread groove, causing a defective operation. Moreover, when the end of the thread groove is machined to cut, the ball recirculation parts will be damaged, sometimes making operation impossible.
- Thoroughly keep in mind the mounting accuracy.
Moment load due to misalignment and poor squareness between ball screws, bearings, guide and nut housing causes defective operation, abnormal sound, abnormal vibration and short life. In addition, it may break the screw shaft due to rotating bending fatigue, sometimes resulting in a serious accident.
- Be careful of dropping by its own weight.
As a ball screw has a low coefficient of friction, the shaft or nut may sometimes drop by its own weight. Take care so that the finger may not be pinched.

CAUTION

- Do not remove the nut.
If the ball come off from the nut or the shaft is detached from the nut, return them to our company without reassembling.
They will be repaired (Repair cost is charged.)
Some series of stocked standard ball screws are so designed that the nut can be separated for additional machining.
Such series of ball screws are provided with sleeves for nut separation.
Thoroughly read the attached instructions.
- Be careful of accumulation of dust and foreign matter.
In the assembly process of a mechanical installation, put a cover so that dust and foreign matter may not accumulate on the screw shaft.
Accumulation of dust and foreign matter will cause defective operation.
- When fitting bearing, gear, pulley and other parts to the screw shaft, be careful not to shock them. The screw shaft may be bent.
If such parts are accidentally shocked, apply an indicator to the outside diameter, such as coupling attachment of the screw shaft and check that there is no bend.
- Use it within the operating temperature limit.
Usually, the designed operating temperature limit is below 60°C.
If the ball screw is used at higher than the operating temperature limit, there is a possibility that the lubricating parts or sealing parts may be damaged. When using in special environment, consult KURODA beforehand.



BALL SCREW/COMMON INSTRUCTIONS ②

Be sure to read the following instructions before use.
Also refer to "FOR SAFETY USE".

LUBRICATION



CAUTION

● Type of lubricants

Unless otherwise specified, SHELL Albania S2 Grease is enclosed as lubricant. As anticorrosive oil applied to the screw shaft has lubricating performance, it can be used in that condition. Do not change it for any other lubricant and do not wipe it off.

Grease

Use	Brand name	Maker name
For ordinary use	Albania Grease S2	Showa Shell Sekiyu
	Mobilux No.2	Mobil Sekiyu
	Daphny Coronex Green No.2	Idemitsu Kosan
For low temperature	Multemp PS No.2	Kyodo Yushi
For wide temperature range	Multemp LRL3	Kyodo Yushi

Oil

Use	Brand name	Maker name
For ordinary use	Daphny Mechanical Oil	Idemitsu Kosan
	Mobile Vactra Oil Heavy	Mobil Sekiyu

● Checking lubricant conditions and applying grease

Taking into consideration the accumulation of dust and foreign matter in the assembly process of a mechanical installation and working efficiency, lubricant to the ball screw is enclosed in the nut alone, and is not applied on the screw shaft unless otherwise specified.

The quantity of grease in the nut may be insufficient according to the screw size and screw shaft length.

Reciprocate the nut and then check that sufficient grease is applied to the rolling contact surface of the thread groove. If it is insufficient, apply additional grease to the screw shaft.

● Checking and supplying lubricant

Check lubricant 2 to 3 months after starting operation. If it is excessively dirty, wipe off old grease and apply new grease. Usually, check and supply grease every year after that. However, set this interval according to circumstances, as it varies with the operating environment.

● For clean grease "KURODA C Grease", refer to our Ball Screws Catalogue.

STORAGE



CAUTION

● How to store

Store it indoors with least temperature difference if possible. Store it in the horizontal condition with it packed.

To prevent intrusion of dust and rusting, do not unpack and open the internal package except in case of necessity.

UNFINISHED SHAFT ENDS
Screw shaft diameter $\phi 15$, Lead5

(Unit : mm)

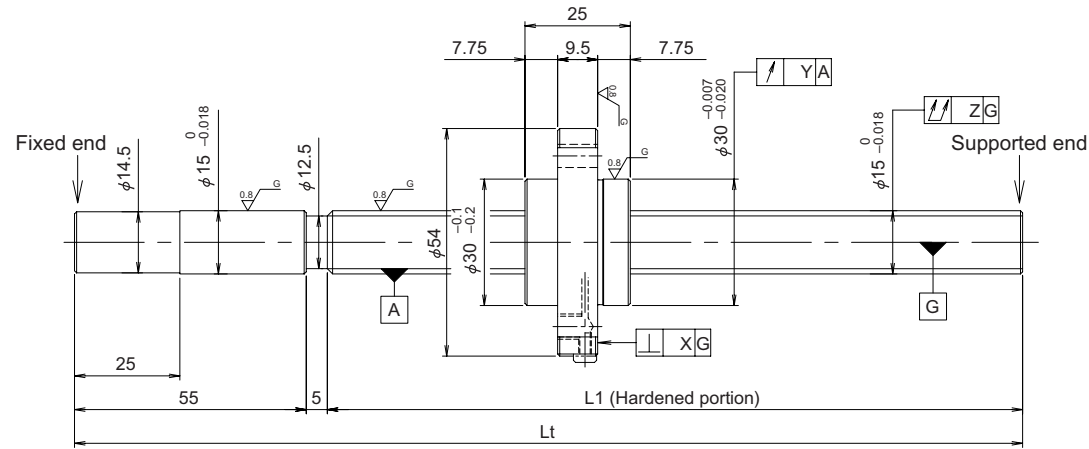
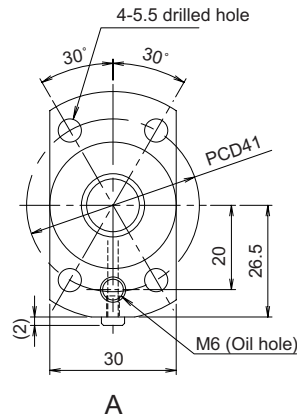

Notation of standard ground ball screw

● Standard length shaft without end machining

FE1505PS-HPNR-□□□□A

FG1505PS-HPNR-□□□□A

● With end machining specified on your drawing

FE1505PS-□P□R-□□□□X□□□□-C7M

FG1505PS-□P□R-□□□□X□□□□-C5□

Overall length Thread length

Model No.	Axial clearance	L ₁	L _t	X	Y	Z	Preload torque (N·cm)	Lead accuracy			Wiper	Mass (kg)
								±Ec	ec	e300		
FE1505PS-HPNR-0600A	~0.030(M)	540	600	0.014	0.020	0.110	—	0.05	—	—	—	1.05
FE1505PS-HPNR-1100A		1040	1100			0.210						1.94
FG1505PS-HPNR-0600A	~0.005(F)	540	600	0.010	0.012	0.075	~2.0	0.030	0.023	0.018	—	1.05
FG1505PS-HPNR-1100A		1040	1100			0.150						0.046

• Support unit : BUK-12A(BUK-12F, BUK-10S) and BUM-12 is recommended. (Refer to our Ball Screws Catalogue.)

• Product with axial clearance~0.005(F) shown in the table may be partially preloaded.

• Preload torque shown in the table is a value before greasing.

• The grease is contained inside of nut only at the time of delivery. When using it, apply lubricant.

Table of optional specifications for each model

Series	Additional machining of shaft end	Axial clearance adjustment (Note 2)	Surface treatment (Note 1)	Difference of grease	Direction of nut	Wiper removal
FE	○	X	○	○	○	—
FG	○	○	○	○	○	—

 (Note 1) The above-mentioned surface treatment is Anticorrosive black coating (coating thickness : 1 to 2 μ m).

(Note 2) For axial clearance adjustment for FG series, contact KURODA.

Ball screw specifications

Screw shaft dia.	15	Axial clearance	~0.030(M)	~0.005(F)
Lead	5	Basic dynamic load rating	7400N	
Thread direction	Right-hand	Basic static load rating	12900N	
Number of circuits	2.7turn 1circuit	Spacer ball	—	
Ball diameter	3.175	Lubricant	Alvania Grease S2	

SHAFT END FINISH ORDERING SHEET

Screw shaft diameter $\phi 15$, Lead5

(Unit : mm)

FE1505PS-HPNR- X -C7M
 FG1505PS-HPNR- X -C5

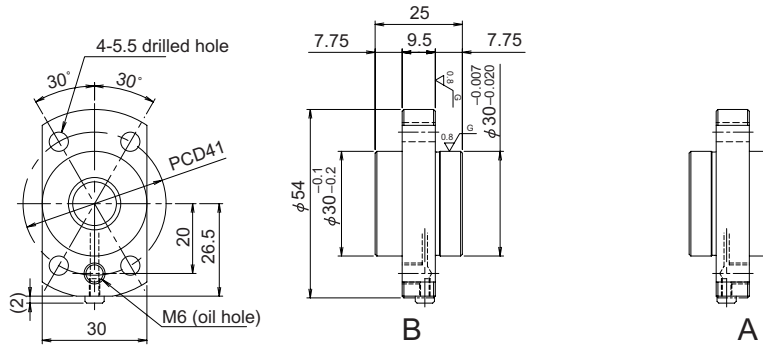

Select the orientation of nut flange by circling A or B.
 No marking means "B" orientation as default.

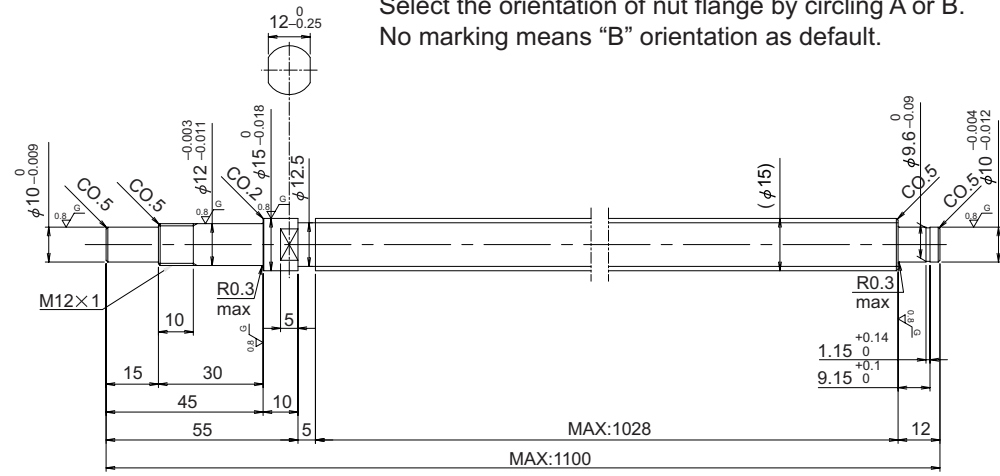

Applicable Support Unit

Direct mount : BUK-12A(Fixed end unit + Supported end unit) Refer to our Ball Screws Catalogue
 Circle flange : BUM-12(Fixed end unit + Supported end bearing) Refer to our Ball Screws Catalogue

Company Name			
Telephone		Name of Person in Charge	
Company address			

UNFINISHED SHAFT ENDS

Screw shaft diameter $\phi 15$, Lead 10

(Unit : mm)

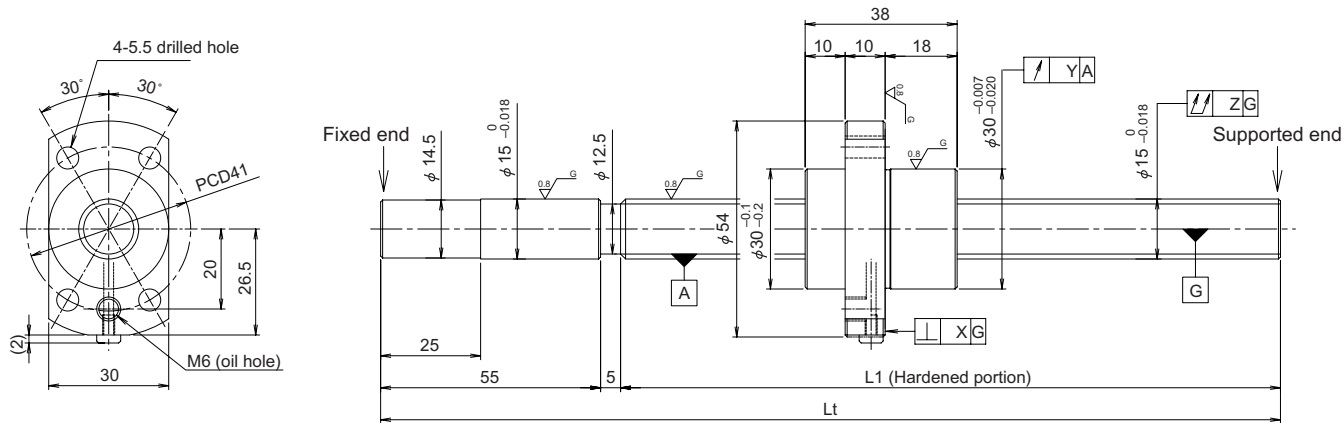

Model No.	Axial clearance	L1	Lt	X	Y	Z	Preload torque (N•cm)	Lead accuracy			Wiper	Mass (kg)
								$\pm Ec$	ec	e300		
FE1510PS-HPNR-0600A	~0.030(M)	540	600	0.014	0.020	0.110	—	0.05	—	—	—	
FE1510PS-HPNR-0900A		840	900			0.170						
FE1510PS-HPNR-1100A		1040	1100			0.210						
FE1510PS-HPNR-1300A		1240	1300			0.270						
FE1510PS-HPNR-1500A		1440	1500			0.270						
FG1510PS-HPNR-0600A	~0.005(F)	540	600	0.010	0.012	0.075	~3.0	0.046	0.030	0.018	—	
FG1510PS-HPNR-0900A		840	900			0.120						
FG1510PS-HPNR-1100A		1040	1100			0.150						
FG1510PS-HPNR-1300A		1240	1300			0.190						
FG1510PS-HPNR-1500A		1440	1500			0.190						

Notation of standard ground ball screw
 ● Standard length shaft without end machining
 FE1510PS-HPNR-□□□□A
 FG1510PS-HPNR-□□□□A
 ● With end machining specified on your drawing
 FE1510PS-□PNR-□□□□X□□□□-C7M
 FG1510PS-□PNR-□□□□X□□□□-C5□

Overall length Thread length

- Support unit : BUK-12A(BUK-12F, BUK-10S) and BUM-12 is recommended. (Refer to our Ball Screws Catalogue.)
- Product with axial clearance~0.005(F) shown in the table may be partially preloaded.
- Preload torque shown in the table is a value before greasing.
- The grease is contained inside of nut only at the time of delivery. When using it, apply lubricant.

Table of optional specifications for each model

Series	Additional machining of shaft end	Axial clearance adjustment (Note 2)	Surface treatment (Note 1)	Difference of grease	Direction of nut	Wiper removal
FE	○	X	○	○	○	—
FG	○	○	○	○	○	—

(Note 1) The above-mentioned surface treatment is Anticorrosive black coating (coating thickness : 1 to 2 μ m).
 (Note 2) For axial clearance adjustment for FG series, contact KURODA.

Ball screw specifications

Screw shaft dia.	15	Axial clearance	~0.030(M)	~0.005(F)
Lead	10	Basic dynamic load rating	7400N	
Thread direction	Right-hand	Basic static load rating	12900N	
Number of circuits	2.7turn 1circuit	Spacer ball	—	
Ball diameter	3.175	Lubricant	Alvania Grease S2	

SHAFT END FINISH ORDERING SHEET

Screw shaft diameter $\phi 15$, Lead10

(Unit : mm)

FE1510PS-HPNR- X -C7M
 FG1510PS-HPNR- X -C5

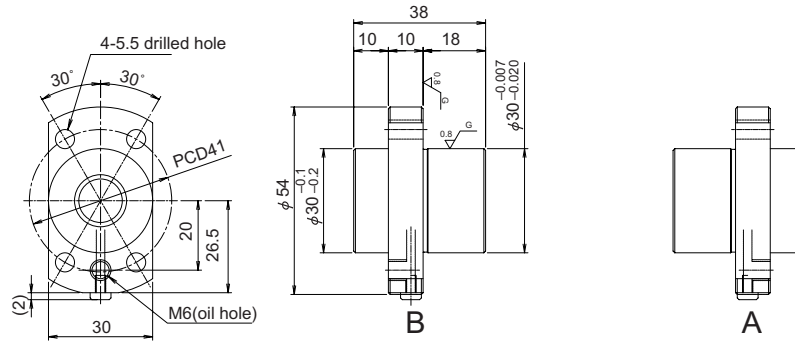

Select the orientation of nut flange by circling A or B.
 No marking means "B" orientation as default.

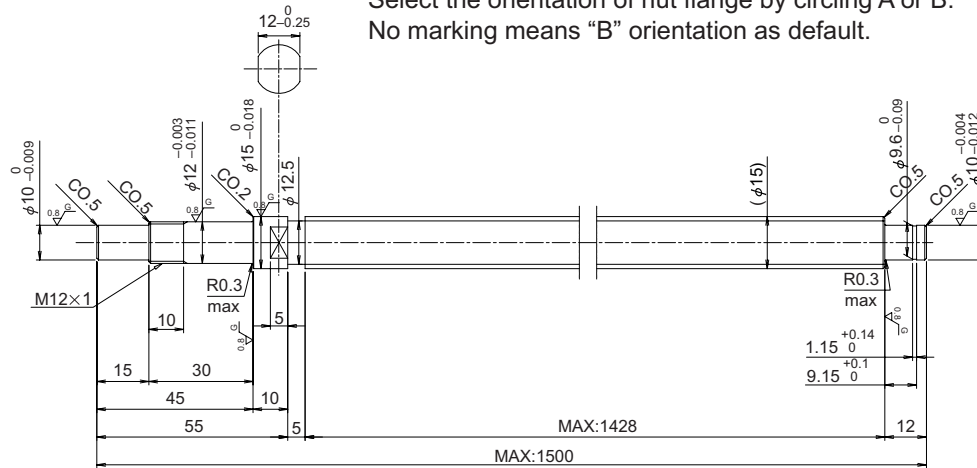

Applicable Support Unit

Direct mount : BUK-12A(Fixed end unit + Supported end unit) Refer to our Ball Screws Catalogue
 Circle flange : BUM-12(Fixed end unit + Supported end bearing) Refer to our Ball Screws Catalogue

Company Name			
Telephone		Name of Person in Charge	
Company address			

UNFINISHED SHAFT ENDS

Screw shaft diameter $\phi 15$, Lead20

(Unit : mm)

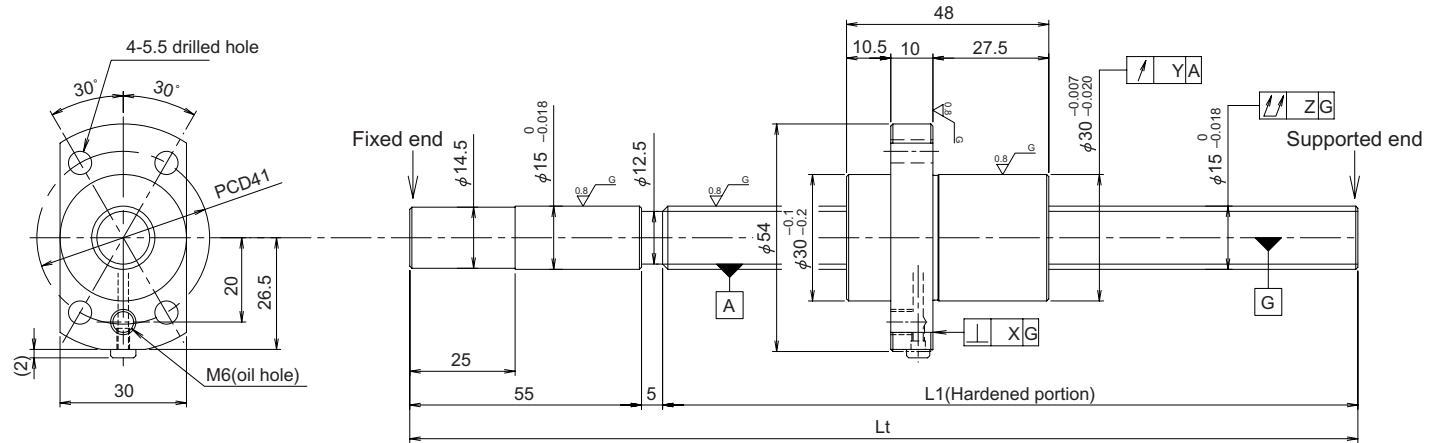

Model No.	Axial clearance	L ₁	L _t	X	Y	Z	Preload torque (N·cm)	Lead accuracy			Wiper	Mass (kg)
								±Ec	ec	e300		
FE1520PS-HPNR-0600A	~0.030(M)	540	600	0.014	0.020	0.110	—	0.05	—	—	—	
FE1520PS-HPNR-0900A		840	900			0.170						
FE1520PS-HPNR-1100A		1040	1100			0.210						
FE1520AS-HPNR-1300A		1240	1300			0.270						
FE1520PS-HPNR-1500A		1440	1500			0.270						
FG1520PS-HPNR-0600A	~0.005(F)	540	600	0.010	0.012	0.075	~3.0	0.030	0.023	0.018	—	
FG1520PS-HPNR-0900A		840	900			0.120		0.040	0.027			
FG1520PS-HPNR-1100A		1040	1100			0.150		0.046	0.030			
FG1520AS-HPNR-1300A		1240	1300			0.190		0.054	0.035			
FG1520PS-HPNR-1500A		1440	1500			0.190		0.054	0.035			

Notation of standard ground ball screw
 ●Standard length shaft without end machining
 FE1520PS-HPNR-□□□□A
 FG1520PS-HPNR-□□□□A
 ●With end machining specified on your drawing
 FE1520PS-□PNR-□□□□X□□□□-C7M
 FG1520PS-□PNR-□□□□X□□□□-C5□
 Overall length Thread length

- Support unit : BUK-12A(BUK-12F, BUK-10S) and BUM-12 is recommended. (Refer to our Ball Screws Catalogue)
- Product with axial clearance~0.005(F) shown in the table may be partially preloaded.
- Preload torque shown in the table is a value before greasing.
- The grease is contained inside of nut only at the time of delivery. When using it, apply lubricant.

Table of optional specifications for each model

Series	Additional machining of shaft end	Axial clearance adjustment (Note 2)	Surface treatment (Note 1)	Difference of grease	Direction of nut	Wiper removal
FE	○	X	○	○	○	—
FG	○	○	○	○	○	—

(Note 1) The above-mentioned surface treatment is Anticorrosive black coating (coating thickness : 1 to 2 μm).
 (Note 2) For axial clearance adjustment for FG series, contact KURODA.

Ball screw specifications

Screw shaft dia.	15	Axial clearance	~0.030(M)	~0.005(F)
Lead	20	Basic dynamic load rating	4800N	
Thread direction	Right-hand	Basic static load rating	8200N	
Number of circuits	1.7turn 1circuit	Spacer ball	—	
Ball diameter	3.175	Lubricant	Alvania Grease S2	

SHAFT END FINISH ORDERING SHEET

Screw shaft diameter $\phi 15$, Lead 20

(Unit : mm)

FE1520PS-HPNR- X -C7M
 FG1520PS-HPNR- X -C5

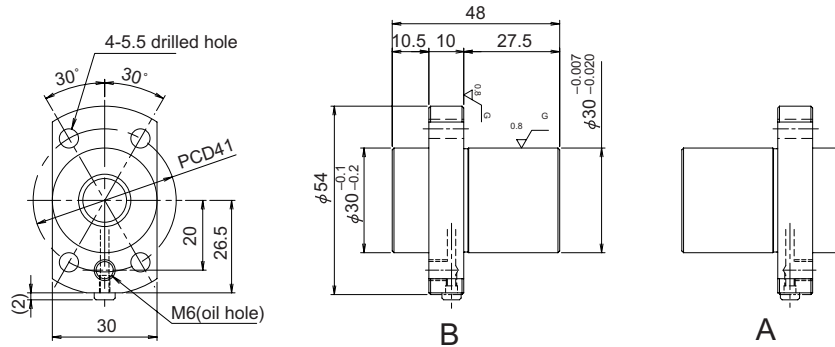

Select the orientation of nut flange by circling A or B.
 No marking means "B" orientation as default.

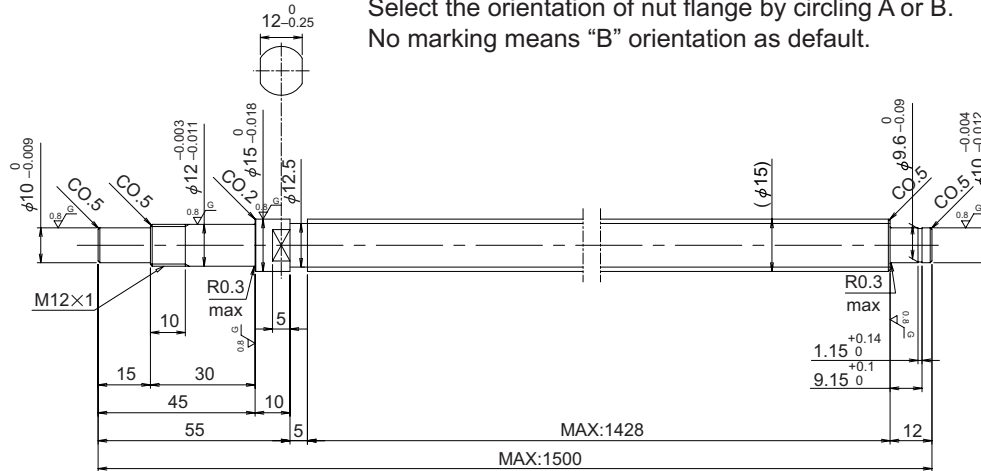

Applicable Support Unit

Direct mount : BUK-12A(Fixed end unit + Supported end unit) Refer to our Ball Screws Catalogue
 Circle flange : BUM-12(Fixed end unit + Supported end bearing) Refer to our Ball Screws Catalogue

Company Name			
Telephone		Name of Person in Charge	
Company address			

UNFINISHED SHAFT ENDS

Screw shaft diameter $\phi 20$, Lead 10

(Unit : mm)

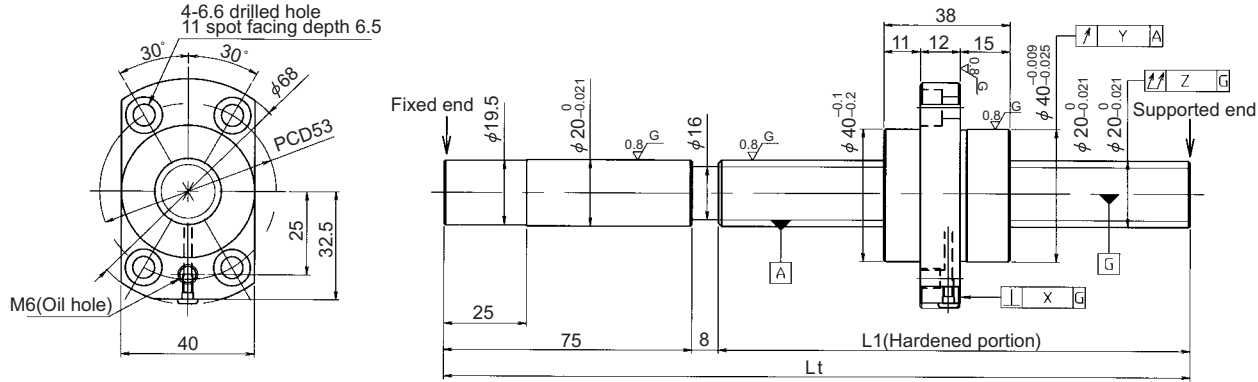

Model No.	Axial clearance	L1	Lt	X	Y	Z	Preload torque (N•cm)	Lead accuracy			Wiper	Mass (kg)	
								±Ec	ec	e300			
FE2010PS-HPNR-0605A	~0.030(M)	522	605	0.018	0.030	0.110	—	0.05	—	—	—	1.79	
FE2010PS-HPNR-1005A		922	1005			0.210						2.77	
FE2010PS-HPNR-1505A		1422	1505			0.270						4.00	
FE2010PS-HPNR-1805A		1722	1805									4.75	
FG2010PS-HPNR-0605A	~0.005(F)	522	605	0.011	0.015	0.075	~4.0	0.030	0.023	0.018	—	1.79	
FG2010PS-HPNR-1005A		922	1005			0.150						2.77	
FG2010PS-HPNR-1505A		1422	1505			0.054						0.035	4.00
FG2010PS-HPNR-1805A		1722	1805			0.065						0.040	4.75

Notation of standard ground ball screw

● Standard length shaft without end machining

FE2010PS-HPNR-□□□□A

FG2010PS-HPNR-□□□□A

● With end machining specified on your drawing

FE2010PS-□PNR-□□□□X□□□□-C7M

FG2010PS-□PNR-□□□□X□□□□-C5□

Overall length Thread length

- Support unit : BUK-15A(BUK-15F, BUK-15S) and BUM-15 is recommended. (Refer to our Ball Screws Catalogue)
- Product with axial clearance~0.005(F) shown in the table may be partially preloaded.
- Preload torque shown in the table is a value before greasing.
- The grease is contained inside of nut only at the time of delivery. When using it, apply lubricant.

Table of optional specifications for each model

Series	Additional machining of shaft end	Axial clearance adjustment (Note 2)	Surface treatment (Note 1)	Difference of grease	Direction of nut	Wiper removal
FE	○	X	○	○	○	—
FG	○	○	○	○	○	—

(Note 1) The above-mentioned surface treatment is Anticorrosive black coating (coating thickness : 1 to 2 μ m).

(Note 2) For axial clearance adjustment for FG series, contact KURODA.

Ball screw specifications

Screw shaft dia.	20	Axial clearance	~0.030(M)	~0.005(F)
Lead	10	Basic dynamic load rating	18000N	
Thread direction	Right-hand	Basic static load rating	33900N	
Number of circuits	2.7turn 1circuit	Spacer ball	—	
Ball diameter	4.7625	Lubricant	Alvania Grease S2	

SHAFT END FINISH ORDERING SHEET

Screw shaft diameter $\phi 20$, Lead 10

(Unit : mm)

FE2010PS-HPNR- X -C7M
 FG2010PS-HPNR- X -C5

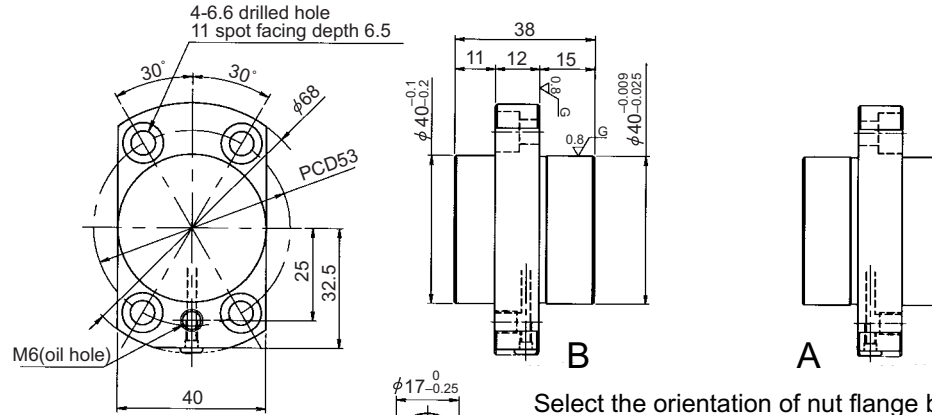

Select the orientation of nut flange by circling A or B.
 No marking means "B" orientation as default.

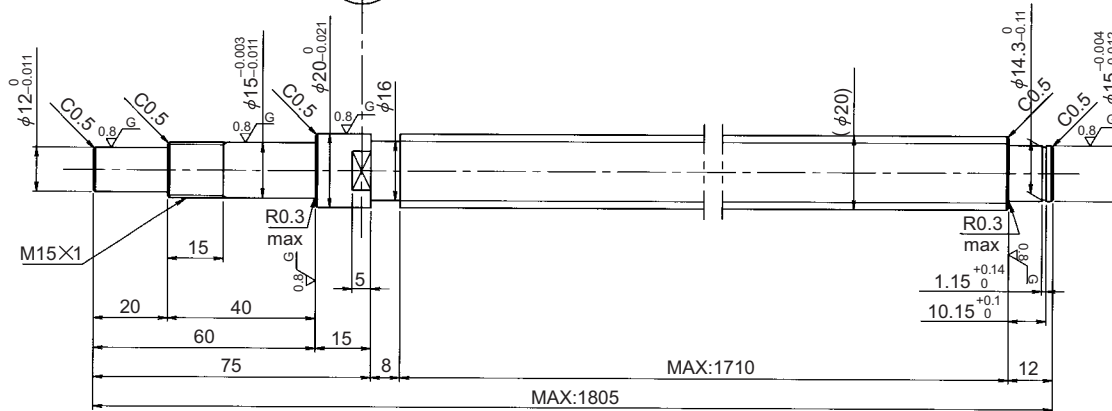

Applicable Support Unit

Direct mount : BUK-15A(Fixed end unit + Supported end unit) Refer to our Ball Screws Catalogue
 Circle flange : BUM-15(Fixed end unit + Supported end bearing) Refer to our Ball Screws Catalogue

Company Name			
Telephone		Name of Person in Charge	
Company address			

UNFINISHED SHAFT ENDS

Screw shaft diameter $\phi 20$, Lead 20

(Unit : mm)

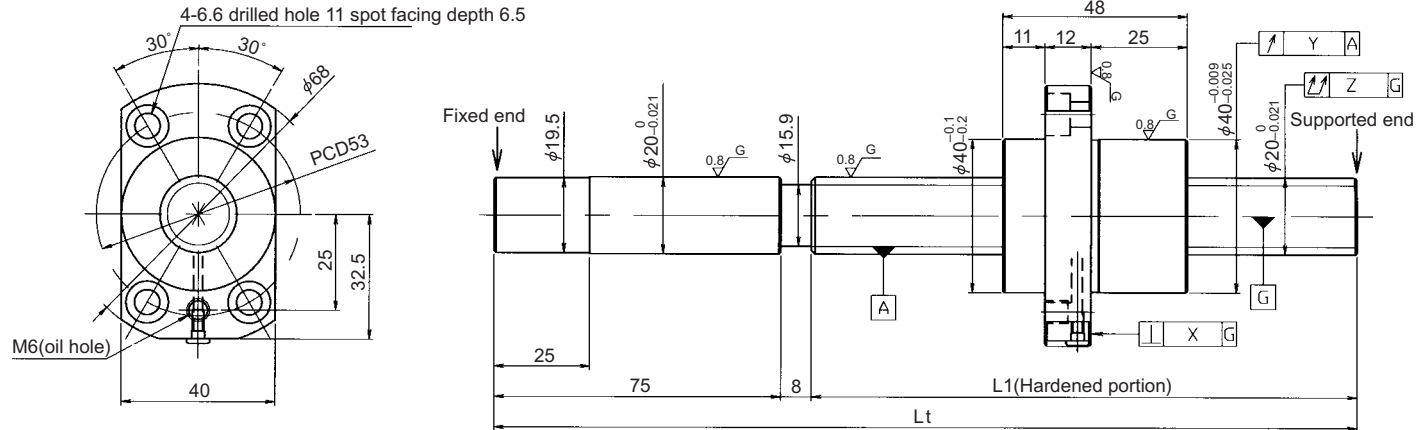

Model No.	Axial clearance	L ₁	L _t	X	Y	Z	Preload torque (N•cm)	Lead accuracy			Wiper	Mass (kg)		
								±Ec	ec	e300				
FE2020PS-HPNR-1005A	~0.030(M)	922	1005	0.018	0.030	0.210	—	0.05	—	—	—	2.85		
FE2020PS-HPNR-1505A		1422	1505			0.270						4.08		
FE2020PS-HPNR-1805A		1722	1805			0.270						4.82		
FG2020PS-HPNR-1005A	~0.005(F)	922	1005	0.011	0.015	0.150	~4.0	0.040	0.027	0.018	—	2.85		
FG2020PS-HPNR-1505A		1422	1505			0.190						0.054	0.035	4.08
FG2020PS-HPNR-1805A		1722	1805			0.190						0.065	0.040	4.82

Notation of standard ground ball screw
 ●Standard length shaft without end machining
 FE2020PS-HPNR-□□□□A
 FG2020PS-HPNR-□□□□A
 ●With end machining specified on your drawing
 FE2020PS-□PNR-□□□□X□□□□-C7M
 FG2020PS-□PNR-□□□□X□□□□-C5□
 Overall length Thread length

- Support unit : BUK-15A(BUK-15F, BUK-15S) and BUM-15 is recommended. (Refer to our Ball Screws Catalogue)
- Product with axial clearance~0.005(F) shown in the table may be partially preloaded.
- Preload torque shown in the table is a value before greasing.
- The grease is contained inside of nut only at the time of delivery. When using it, apply lubricant.

Table of optional specifications for each model

Series	Additional machining of shaft end	Axial clearance adjustment (Note 2)	Surface treatment (Note 1)	Difference of grease	Direction of nut	Wiper removal
FE	○	X	○	○	○	—
FG	○	○	○	○	○	—

(Note 1) The above-mentioned surface treatment is Anticorrosive black coating (coating thickness : 1 to 2 μ m).
 (Note 2) For axial clearance adjustment for FG series, contact KURODA.

Ball screw specifications

Screw shaft dia.	20	Axial clearance	~0.030(M)	~0.005(F)
Lead	20	Basic dynamic load rating	11600N	
Thread direction	Right-hand	Basic static load rating	20600N	
Number of circuits	1.7turn 1circuit	Spacer ball	—	
Ball diameter	4.7625	Lubricant	Alvania Grease S2	

SHAFT END FINISH ORDERING SHEET

Screw shaft diameter $\phi 20$, Lead 20

(Unit : mm)

FE2020PS-HPNR- X -C7M
 FG2020PS-HPNR- X -C5

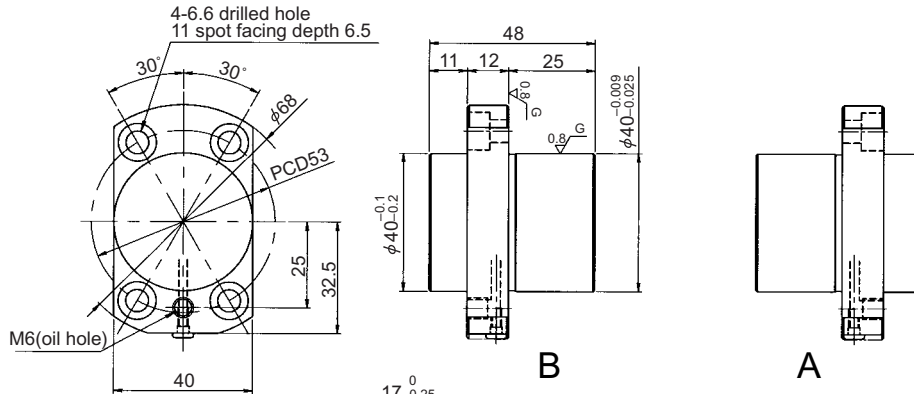

Select the orientation of nut flange by circling A or B.
 No marking means "B" orientation as default.

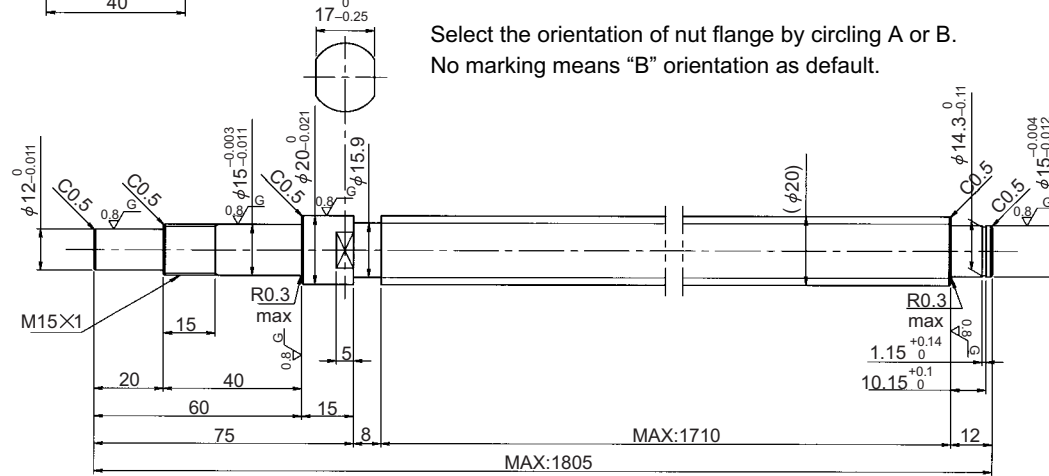

Applicable Support Unit

Direct mount : BUK-15A(Fixed end unit + Supported end unit) Refer to our Ball Screws Catalogue
 Circle flange : BUM-15(Fixed end unit + Supported end bearing) Refer to our Ball Screws Catalogue

Company Name			
Telephone		Name of Person in Charge	
Company address			

UNFINISHED SHAFT ENDS

Screw shaft diameter $\phi 25$, Lead 5

(Unit : mm)

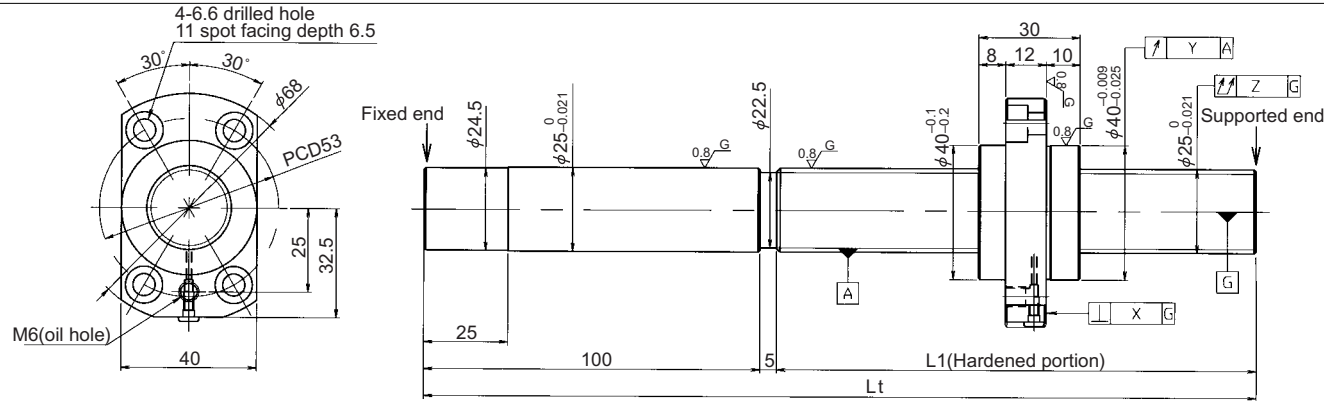

Model No.	Axial clearance	L1	Lt	X	Y	Z	Preload torque (N·cm)	Lead accuracy			Wiper	Mass (kg)
								±Ec	ec	e300		
FE2505PS-HPNR-0600A	~0.030(M)	495	600	0.018	0.030	0.090	—	0.05	—	—	—	
FE2505PS-HPNR-1000A		895	1000			0.130						
FE2505PS-HPNR-1505A		1400	1505			0.190						
FE2505PS-HPNR-1805A		1700	1805			0.250						
FG2505PS-HPNR-0600A	~0.005(F)	495	600	0.011	0.015	0.060	~4.0	0.027	0.020	0.018	—	
FG2505PS-HPNR-1000A		895	1000			0.085	~6.0	0.040	0.027			
FG2505PS-HPNR-1505A		1400	1505			0.130		0.054	0.035			
FG2505PS-HPNR-1805A		1700	1805			0.170		0.065	0.040			

Notation of standard ground ball screw

●Standard length shaft without end machining

FE2505PS-HPNR-□□□□A

FG2505PS-HPNR-□□□□A

●With end machining specified on your drawing

FE2505PS-□PNR-□□□□X□□□□-C7M

FG2505PS-□PNR-□□□□X□□□□-C5□

Overall length Thread length

• Support unit : BUK-20A(BUK-20F, BUK-20S) and BUM-20 is recommended. (Refer to our Ball Screws Catalogue)

• Product with axial clearance~0.005(F) shown in the table may be partially preloaded.

• Preload torque shown in the table is a value before greasing.

• The grease is contained inside of nut only at the time of delivery. When using it, apply lubricant.

Table of optional specifications for each model

Series	Additional machining of shaft end	Axial clearance adjustment (Note 2)	Surface treatment (Note 1)	Difference of grease	Direction of nut	Wiper removal
FE	○	X	○	○	○	—
FG	○	○	○	○	○	—

(Note 1) The above-mentioned surface treatment is Anticorrosive black coating (coating thickness : 1 to 2 μ m).

(Note 2) For axial clearance adjustment for FG series, contact KURODA.

Ball screw specifications

Screw shaft dia.	25	Axial clearance	~0.030(M)	~0.005(F)
Lead	5	Basic dynamic load rating	13100N	
Thread direction	Right-hand	Basic static load rating	31800N	
Number of circuits	3.7turn 1circuit	Spacer ball	—	
Ball diameter	3.175	Lubricant	Alvania Grease S2	

SHAFT END FINISH ORDERING SHEET

Screw shaft diameter $\phi 25$, Lead 5

(Unit : mm)

FE2505PS-HPNR- X -C7M
 FG2505PS-HPNR- X -C5

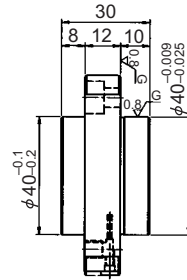
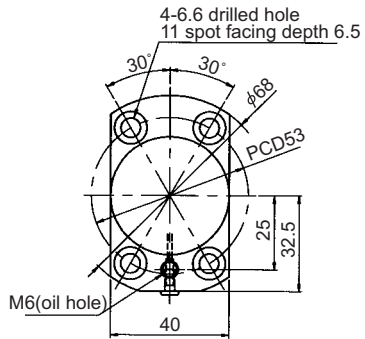

B

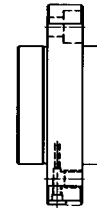

A

Select the orientation of nut flange by circling A or B.
No marking means "B" orientation as default.

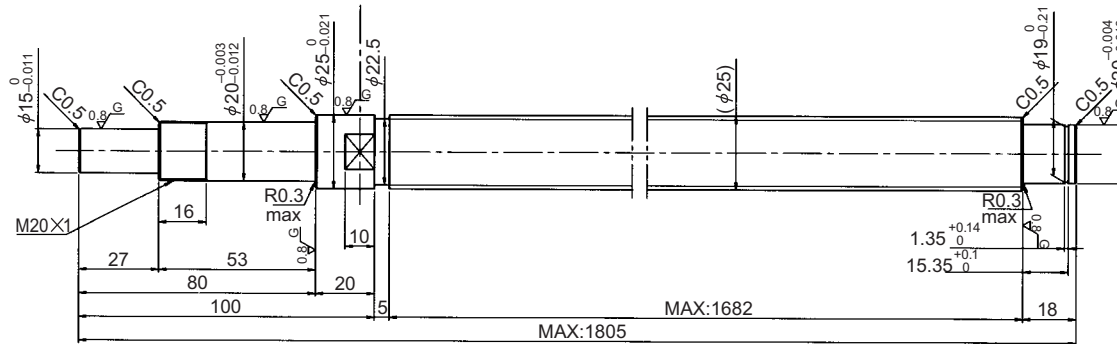
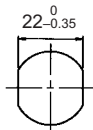

Applicable Support Unit

Direct mount : BUK-20A(Fixed end unit + Supported end unit) Refer to our Ball Screws Catalogue
 Circle flange : BUM-20(Fixed end unit + Supported end bearing) Refer to our Ball Screws Catalogue

Company Name			
Telephone		Name of Person in Charge	
Company address			

UNFINISHED SHAFT ENDS
Screw shaft diameter $\phi 25$, Lead 10

(Unit : mm)

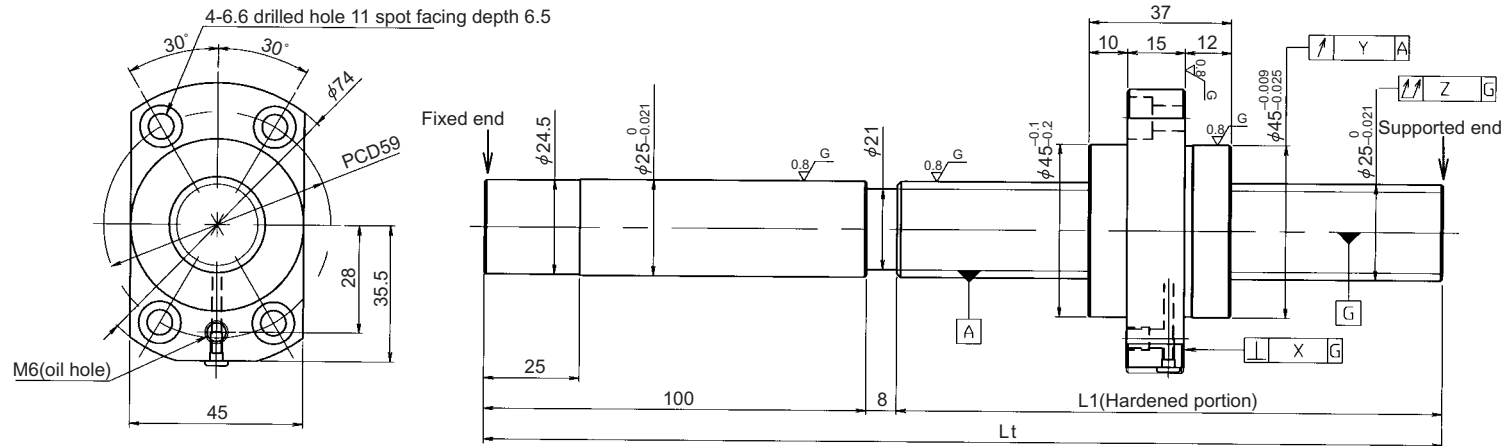

Model No.	Axial clearance	L ₁	L _t	X	Y	Z	Preload torque (N•cm)	Lead accuracy			Wiper	Mass (kg)
								±Ec	ec	e300		
FE2510PS-HPNR-1020A	~0.030(M)	912	1020	0.018	0.030	0.150	—	0.05	—	—	—	
FE2510PS-HPNR-1520A		1412	1520			0.190						
FE2510PS-HPNR-2220A		2112	2220			0.320						
FG2510PS-HPNR-1020A	~0.005(F)	912	1020	0.013	0.019	0.100	~4.0	0.040	0.027	0.018	—	
FG2510PS-HPNR-1520A		1412	1520			0.130						
FG2510PS-HPNR-2220A		2112	2220			0.170						

Notation of standard ground ball screw

●Standard length shaft without end machining

FE2510PS-HPNR-□□□□A

FG2510PS-HPNR-□□□□A

●With end machining specified on your drawing • Support unit : BUK-20A(BUK-20F, BUK-20S) and BUM-20 is recommended. (Refer to our Ball Screws Catalogue)

FE2510PS-□PNR-□□□□X□□□□-C7M

FG2510PS-□PNR-□□□□X□□□□-C5□

Overall length Thread length

• Product with axial clearance~0.005(F) shown in the table may be partially preloaded.

• Preload torque shown in the table is a value before greasing.

• The grease is contained inside of nut only at the time of delivery. When using it, apply lubricant.

Table of optional specifications for each model

Series	Additional machining of shaft end	Axial clearance adjustment (Note 2)	Surface treatment (Note 1)	Difference of grease	Direction of nut	Wiper removal
FE	○	X	○	○	○	—
FG	○	○	○	○	○	—

 (Note 1) The above-mentioned surface treatment is Anticorrosive black coating (coating thickness : 1 to 2 μ m).

(Note 2) For axial clearance adjustment for FG series, contact KURODA.

Ball screw specifications

Screw shaft dia.	25	Axial clearance	~0.030(M)	~0.005(F)
Lead	10	Basic dynamic load rating	20400N	
Thread direction	Right-hand	Basic static load rating	42600N	
Number of circuits	2.7turn 1circuit	Spacer ball	—	
Ball diameter	4.7625	Lubricant	Alvania Grease S2	

SHAFT END FINISH ORDERING SHEET

Screw shaft diameter $\phi 25$, Lead 10

(Unit : mm)

FE2510PS-HPNR- X -C7M
 FG2510PS-HPNR- X -C5

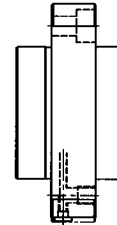
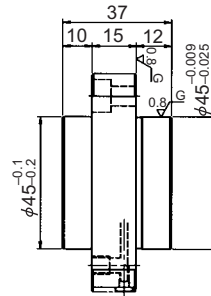
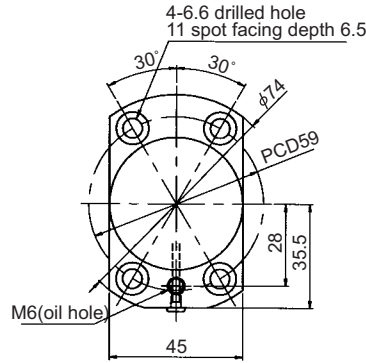

B

A

Select the orientation of nut flange by circling A or B.
 No marking means "B" orientation as default.

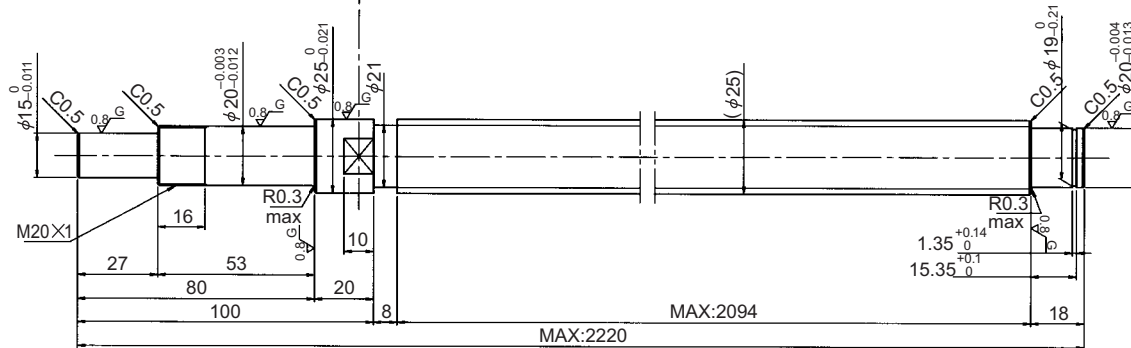
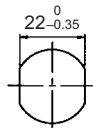

Applicable Support Unit

Direct mount : BUK-20A(Fixed end unit + Supported end unit) Refer to our Ball Screws Catalogue
 Circle flange : BUM-20(Fixed end unit + Supported end bearing) Refer to our Ball Screws Catalogue

Company Name			
Telephone		Name of Person in Charge	
Company address			

UNFINISHED SHAFT ENDS
Screw shaft diameter $\phi 25$, Lead 25

(Unit : mm)

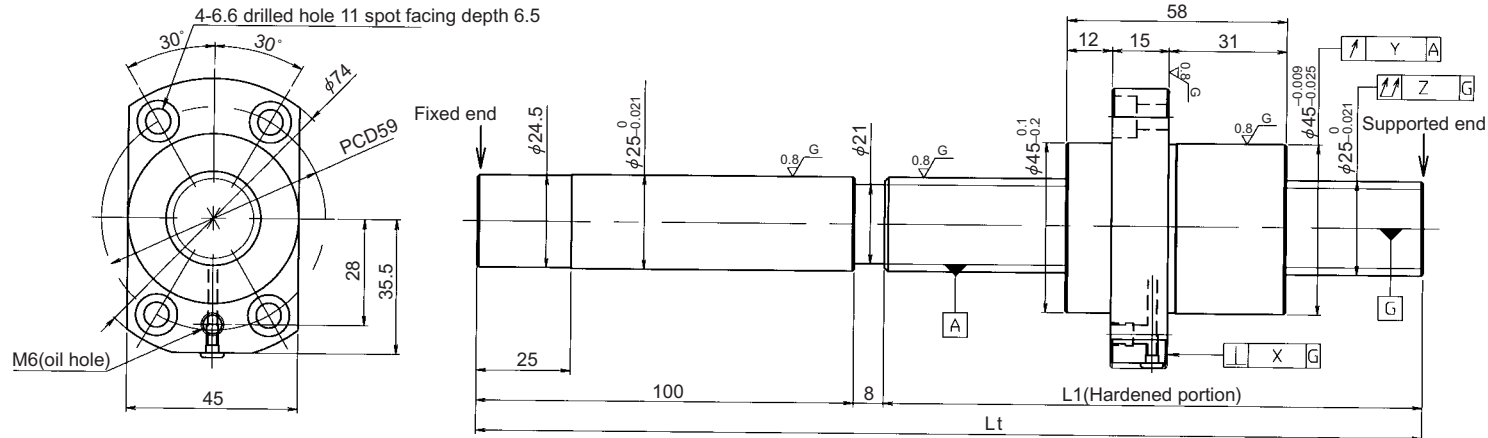

Model No.	Axial clearance	L ₁	L _t	X	Y	Z	Preload torque (N·cm)	Lead accuracy			Wiper	Mass (kg)
								±Ec	ec	e300		
FE2525PS-HPNR-1020A	~0.030(M)	912	1020	0.018	0.030	0.150	—	0.05	—	—	—	4.47
FE2525PS-HPNR-1520A		1412	1520			0.190						6.40
FE2525PS-HPNR-2220A		1912	2020			0.320						9.10
FG2525PS-HPNR-1020A	~0.005(F)	912	1020	0.013	0.019	0.100	~4.0	0.040	0.027	0.018	—	4.47
FG2525PS-HPNR-1520A		1412	1520			0.130						6.40
FG2525PS-HPNR-2220A		1912	2020			0.170						9.10

Notation of standard ground ball screw

●Standard length shaft without end machining

FE2525PS-HPNR-□□□□□A

FG2525PS-HPNR-□□□□□A

●With end machining specified on your drawing • Support unit : BUK-20A(BUK-20F, BUK-20S) and BUM-20 is recommended. (Refer to our Ball Screws Catalogue)

FE2525PS-□PNR-□□□□□X□□□□□-C7M

FG2525PS-□PNR-□□□□□X□□□□□-C5□

Overall length Thread length

• Product with axial clearance~0.005(F) shown in the table may be partially preloaded.

• Preload torque shown in the table is a value before greasing.

• The grease is contained inside of nut only at the time of delivery. When using it, apply lubricant.

Table of optional specifications for each model

Series	Additional machining of shaft end	Axial clearance adjustment (Note 2)	Surface treatment (Note 1)	Difference of grease	Direction of nut	Wiper removal
FE	○	X	○	○	○	—
FG	○	○	○	○	○	—

 (Note 1) The above-mentioned surface treatment is Anticorrosive black coating (coating thickness : 1 to 2 μ m).

(Note 2) For axial clearance adjustment for FG series, contact KURODA.

Ball screw specifications

Screw shaft dia.	25	Axial clearance	~0.030(M)	~0.005(F)
Lead	25	Basic dynamic load rating	13100N	
Thread direction	Right-hand	Basic static load rating	25900N	
Number of circuits	1.7turn 1circuit	Spacer ball	—	
Ball diameter	4.7625	Lubricant	Alvania Grease S2	

SHAFT END FINISH ORDERING SHEET

Screw shaft diameter $\phi 25$, Lead 25

(Unit : mm)

FE2525PS-HPNR- X -C7M
 FG2525PS-HPNR- X -C5

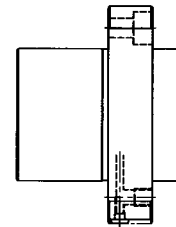
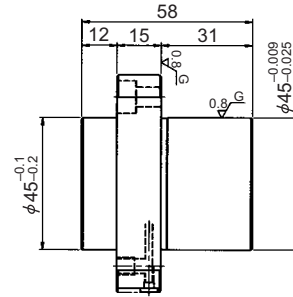
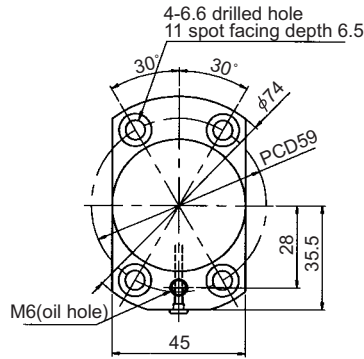

B

A

Select the orientation of nut flange by circling A or B.
No marking means "B" orientation as default.

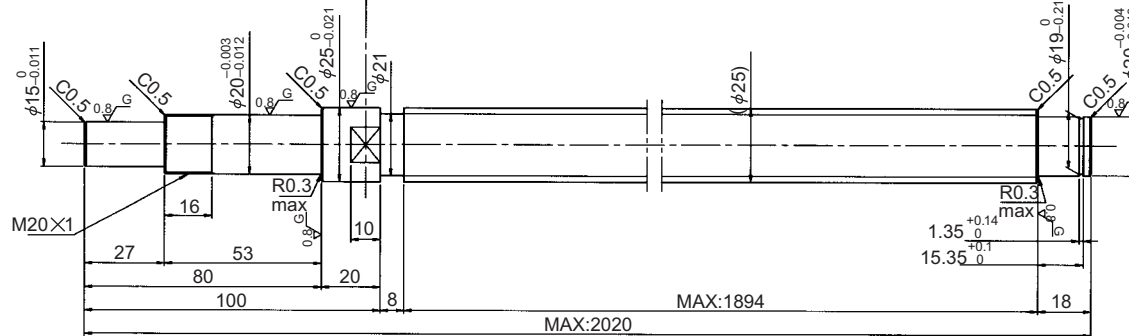
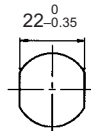

Applicable Support Unit

Direct mount : BUK-20A(Fixed end unit + Supported end unit) Refer to our Ball Screws Catalogue
 Circle flange : BUM-20(Fixed end unit + Supported end bearing) Refer to our Ball Screws Catalogue

Company Name			
Telephone		Name of Person in Charge	
Company address			

End deflector Method Single Nut
Screw shaft diameter $\phi 15\sim\phi 25$

(Unit : mm)

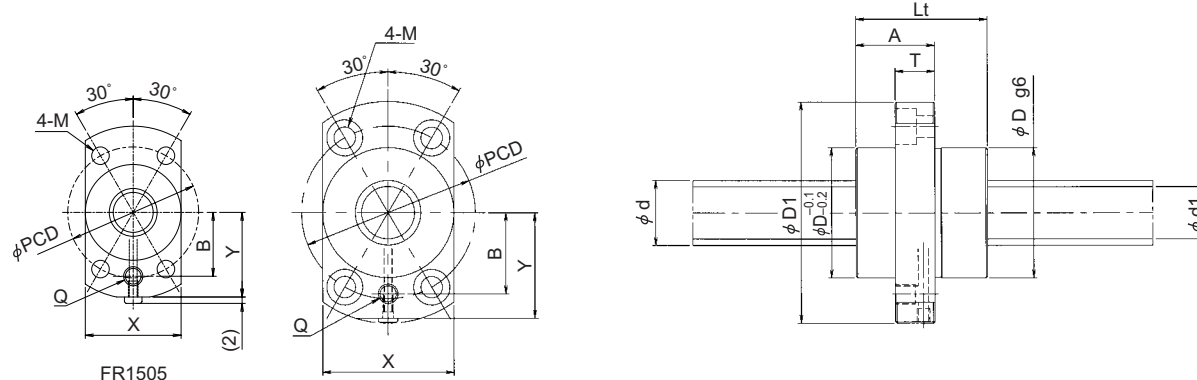
 FR1505
 FR1510
 FR1520

Flange type H

Model No.	Screw shaft diameter d	Lead L	Ball diameter D _b	Root diameter d ₁	Number Of Turns X Circuit	Basic dynamic load rating C (N)	Basic static load rating C ₀ (N)	*Rigidity K _{Ns} (N/μm)	Nut dimensions														Mass					
									Outer diameter D	Overall length L _t	Length A	Wiper	Flange dimensions										Mounting hole			Nut (kg)	Screw shaft (kg/100mm)	
													Thickness T	Outer diameter D ₁	Type	W	X	Y	A	B	G	Oil hole Q	PCD	M				
																								Drill	Spot facing			Depth
FR1505PS-HPNR	15	5	3.1750	12.5	2.7 X 1	7400	12900	120	30	25	17.3	N	9.5	54	H	—	30	26.5	—	20	—	M6	41	5.5	—	—	0.14	0.14
FR1510PS-HPNR	15	10	3.1750	12.5	2.7 X 1	7400	12900	120	30	38	20	N	10	54	H	—	30	26.5	—	20	—	M6	41	5.5	—	—	0.20	0.14
FR1520PS-HPNR	15	20	3.1750	12.5	1.7 X 1	4800	8200	80	30	48	20.5	N	10	54	H	—	30	26.5	—	20	—	M6	41	5.5	—	—	0.24	0.14
FR2010PS-HPNR	20	10	4.7625	16	2.7 X 1	18000	33900	160	40	38	23	N	12	68	H	—	40	32.5	—	25	—	M6	53	6.6	11	6.5	0.30	0.25
FR2020PS-HPNR	20	20	4.7625	15.9	1.7 X 1	11600	20600	100	40	48	23	N	12	68	H	—	40	32.5	—	25	—	M6	53	6.6	11	6.5	0.38	0.25
FR2505PS-HPNR	25	5	3.1750	22.5	3.7 X 1	13100	31800	240	40	30	20	N	12	68	H	—	40	32.5	—	25	—	M6	53	6.6	11	6.5	0.23	0.38
FR2510PS-HPNR	25	10	4.7625	21	2.7 X 1	20400	42600	200	45	37	25	N	15	74	H	—	45	35.5	—	28	—	M6	59	6.6	11	6.5	0.39	0.38
FR2525PS-HPNR	25	25	4.7625	21	1.7 X 1	13100	25900	130	45	58	27	N	15	74	H	—	45	35.5	—	28	—	M6	59	6.6	11	6.5	0.55	0.38

(Note) • The rigidity indicated with the *mark in the above list represents the practical value based on the result of rigidity test. This value is calculated from the elastic displacement measured when the axial load equivalent to 30% of basic dynamic load rating (C) is applied between the screw thread and the balls.

• Wiper material N : Without wiper

End deflector Method Single Nut

Screw shaft diameter $\phi 32 \sim \phi 40$

(Unit : mm)

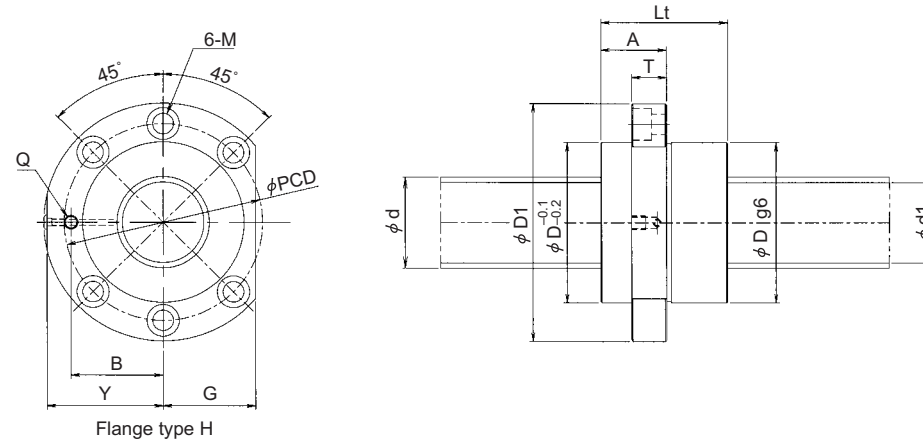

Model No.	Screw shaft diameter d	Lead L	Ball diameter Db	Root diameter d1	Number Of circuits Turn X Circuit	Basic dynamic load rating C (N)	Basic static load rating Co (N)	*Rigidity Kns (N/μm)	Nut dimensions																Mass			
									Outer diameter D	Overall length Lt	Length A	Wiper	Flange dimensions										Mounting hole			Nut (kg)	Screw shaft (kg/100mm)	
													Thickness T	Outer diameter D1	Type	W	X	Y	A	B	G	Oil hole Q	PCD	M				
																								Drill	Spot facing			Depth
FR3205PS-DPNR	32	5	3.1750	29.5	3.7 X 1	14700	41600	300	52	30	20	N	12	82	D	—	—	39.5	—	32	31	M6	67	6.6	11	6.5	0.47	0.63
FR3208PS-DPNR	32	8	4.7625	28	3.7 X 1	30100	74600	330	56	42	25.5	N	15	84	D	—	—	40.5	—	34	32	M6	69	6.6	11	6.5	0.71	0.63
FR3212PS-DPNR	32	12	6.3500	27.2	3.7 X 1	43100	97000	370	62	65	31	N	15	89	D	—	—	43	—	37	34	M6	75	6.6	11	6.5	1.15	0.63
FR3216PS-DPNR	32	16	6.3500	27.2	3.7 X 1	43100	97000	370	62	78	30	N	15	89	D	—	—	43	—	37	34	M6	75	6.6	11	6.5	1.36	0.63
FR3612PS-DPNR	36	12	7.1438	30.6	3.7 X 1	59500	140500	400	70	62	32.5	N	18	104	D	—	—	50.5	—	41	40	M6	86	9	14	8.6	1.54	0.79
FR3616PS-DPNR	36	16	7.1438	30.6	3.7 X 1	59500	140500	400	70	80	35	N	18	104	D	—	—	50.5	—	41	40	M6	86	9	14	8.6	1.89	0.79
FR4008PS-DPNR	40	8	4.7625	36	3.7 X 1	34400	98300	410	64	44	26	N	15	98	D	—	—	47.5	—	38	38	M6	80	9	14	8.6	0.91	0.98
FR4010PS-DPNR	40	10	6.3500	35.2	3.7 X 1	49400	125800	410	70	55	28.5	N	15	104	D	—	—	50.5	—	41	40	M6	86	9	14	8.6	1.25	0.98
FR4012PS-DPNR	40	12	7.1438	34.6	3.7 X 1	64000	160700	460	74	63	33	N	18	108	D	—	—	52.5	—	43	41	M6	90	9	14	8.6	1.66	0.98
FR4016PS-DPNR	40	16	7.1438	34.6	3.7 X 1	64000	160700	460	74	78	34	N	18	108	D	—	—	52.5	—	43	41	M6	90	9	14	8.6	1.98	0.98

(Note) • The rigidity indicated with the *mark in the above list represents the practical value based on the result of rigidity test. This value is calculated from the elastic displacement measured when the axial load equivalent to 30% of basic dynamic load rating (C) is applied between the screw thread and the balls.

• Wiper material N : Without wiper

Ultra-Quiet ball screw/F Series

CUSTOMIZED BALL SCREW WITH DOUBLE-NUT

The * mark in the following table indicates the sizes of the customized ball screws for which the double-nut is available. The specifications of a ball screw with the double-nut are determined through consultation. Please complete the datasheet of ball screw specifications on Page 29 beforehand, and contact KURODA.

The following table shows the features and reference specifications of the ball screws for which the optional double-nut is available.

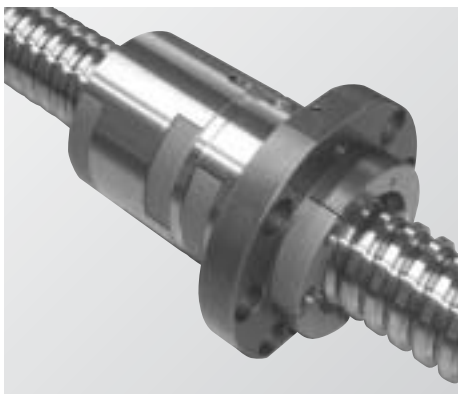

● Combinations of screw shaft and lead

Screw shaft dia. (mm)	Lead(mm)			
	8	10	12	16
32	*		*	*
36			*	*
40	*	*	*	*

Ball screws with double-nut Reference dimensions and specifications

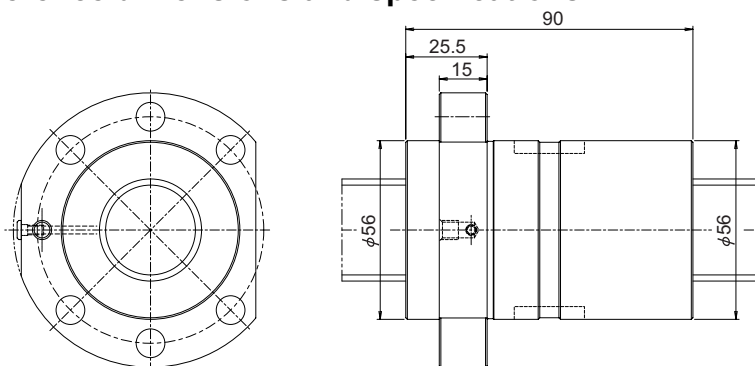

Model: FZ3208PE-ZPNR

Combination: spacer type double-nut

Specifications of ball screw with double-nut		
Screw shaft dia.	32	mm
Lead	8	mm
Ball diameter	φ4.7625	mm
Number of circuit	3.7X1	
Basic dynamic load rating	30100	N
Basic static load rating	74600	N
Rigidity (Note)	570	N/μm

(Note) The rigidity in the above list represents the value applied to the axial load about 3 times or less of the preload, which is equivalent to 1/20 of basic dynamic load rating.

Oscillation torque of preloaded ball screw with single- or double-nut

◆ Operating conditions: stroke 10 mm (moving backward and forward continually in 1 rotation), rotational speed 50min⁻¹

• Ball screw with the single-nut: Torque increases along with the increasing number of oscillations.

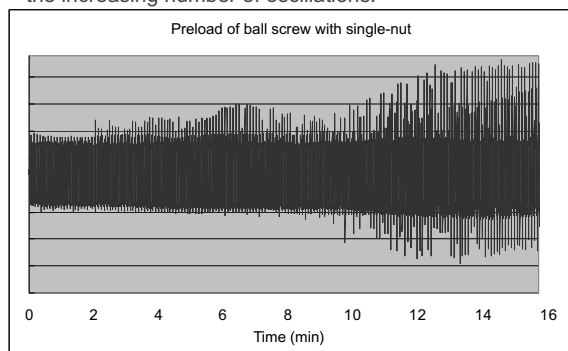

• Ball screw with the double-nut: Torque does not increase along with the increasing number of oscillations.

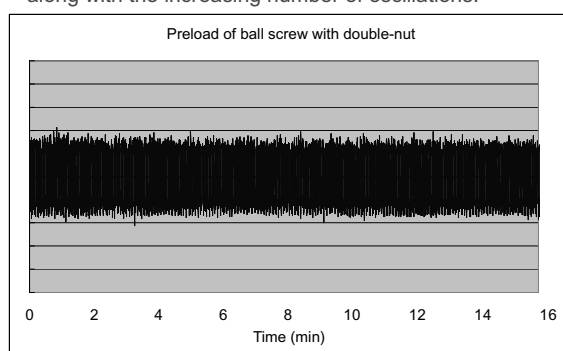

BALL SCREW ORDERING INFORMATION

Company name		Date	
Section		Name of person in charge	
Address		Tel/Fax	
Name of machine in use		Site	
Attached drawing	<input type="checkbox"/> Yes sheet(s)	<input type="checkbox"/> No	

Operation conditions (You can choose either of the system of units.)

Work table mass (weight)								
Type of sliding guide	<input type="checkbox"/> Rotation (Model No.:)			<input type="checkbox"/> Sliding				
Installation state	<input type="checkbox"/> Horizontal		<input type="checkbox"/> Vertical		<input type="checkbox"/> Others (Specify in detail:)			
Max. table speed	mm/s		Max. table stroke			mm		
Supporting method	<input type="checkbox"/> Fixed-fixed (semi-fixed)		<input type="checkbox"/> Fixed-supported		<input type="checkbox"/> Fixed-free		<input type="checkbox"/> Supported—supported	
Operating conditions	<input type="checkbox"/> Shaft rotation-Nut shift		<input type="checkbox"/> Nut rotation-nut shift			<input type="checkbox"/> Normal operation		
	<input type="checkbox"/> Shaft rotation-shaft shift		<input type="checkbox"/> Nut rotation-shaft shift			<input type="checkbox"/> Reverse operation		
	Oscillation		<input type="checkbox"/> Occurs <input type="checkbox"/> Not occurs		Oscillation angle		mm	
Degree of impacts and shocks								
Requested life time								
Operating state <small>(Select either the case A or the case B, and then specify the operating state.)</small>								
<input type="checkbox"/> Case A (Where axial loads and rotational speeds can be divided into several stages.) <small>If you cannot enter the number of all patterns in the following column, please attach a separate sheet.</small>								
Number of patterns	Axial load		Table speed			Operation time or frequency		
1								
2								
3								
<input type="checkbox"/> Case B (Where the impact of inertial force is large.) <small>If you cannot enter the number of all patterns in the following column, please attach a separate sheet.</small>								
Number of patterns	Stroke	Table speed		Acceleration time	Constant speed time	Deceleration time		
1								
2								
3								
Lubrication	<input type="checkbox"/> Grease (Brand name)			<input type="checkbox"/> Oil (Brand name)				
Operation environment	Temperature	Dust	Humidity	Gas	Liquid	Clean room	Vacuum	Others
	°C		%					
Change control	<input type="checkbox"/> Yes		<input type="checkbox"/> No					
Motor	<small>(This must be specified when a single axis module is used.)</small>							
Quantity per 1 unit								
Plan to use with a prototype								
Quantity in mass production								

Specifications of ball screw

Screw shaft dia.	Thread direction	Axial clearance	Thread length	Preload
Lead	Number of circuit	Accuracy grade	Overall length	Required torque
Nut type	<input type="checkbox"/> Single <input type="checkbox"/> Double <input type="checkbox"/> Integral	Flange type	Installation direction	

Other requirements

KURODA sales office		Sales person	
---------------------	--	--------------	--

BALL SCREW ORDERING INFORMATION

Company name	ABC Company	Date	
Section		Name of person in charge	
Address		Tel/Fax	
Name of machine in use	N/C Lathe	Site	Table feed (side to side) Z axis
Attached drawing	<input checked="" type="checkbox"/> Yes 1 sheet(s)	<input type="checkbox"/> No	

Operation conditions (You can choose either of the system of units.)

Work table mass (weight)	1 0 0 0 k g							
Type of sliding guide	<input type="checkbox"/> Rotation (Model No.:)	<input checked="" type="checkbox"/> Sliding						
Installation state	<input checked="" type="checkbox"/> Horizontal	<input type="checkbox"/> Vertical	<input type="checkbox"/> Others (Specify in detail:)					
Max. table speed	4 0 0 mm/s	Max. table stroke	8 3 0 mm					
Supporting method	<input checked="" type="checkbox"/> Fixed-fixed (semi-fixed)	<input type="checkbox"/> Fixed-supported	<input type="checkbox"/> Fixed-free					
Operating conditions	<input checked="" type="checkbox"/> Shaft rotation-Nut shift	<input type="checkbox"/> Nut rotation-nut shift	<input type="checkbox"/> Normal operation					
	<input type="checkbox"/> Shaft rotation-shaft shift	<input type="checkbox"/> Nut rotation-shaft shift	<input type="checkbox"/> Reverse operation					
	Oscillation	<input checked="" type="checkbox"/> Occurs <input type="checkbox"/> Not occurs	Oscillation angle 2 0 mm					
Degree of impacts and shocks								
Requested life time	2000 hours							
Operating state	(Select either the case A or the case B, and then specify the operating state.)							
<input checked="" type="checkbox"/> Case A (Where axial loads and rotational speeds can be divided into several stages.) <small>If you cannot enter the number of all patterns in the following column, please attach a separate sheet.</small>								
Number of patterns	Axial load	Table speed	Operation time or frequency					
1	6 0 0 0 N	1 0 0 mm/s	1 0 %					
2	3 5 0 0 N	2 0 0 mm/s	6 5 %					
3	1 5 0 0 N	4 0 0 mm/s	2 5 %					
<input type="checkbox"/> Case B (Where the impact of inertial force is large.) <small>If you cannot enter the number of all patterns in the following column, please attach a separate sheet.</small>								
Number of patterns	Stroke	Table speed	Acceleration time	Constant speed time	Deceleration time			
1								
2								
3								
Lubrication	<input checked="" type="checkbox"/> Grease (Brand name)		<input type="checkbox"/> Oil (Brand name)					
Operation environment	Temperature	Dust	Humidity	Gas	Liquid	Clean room	Vacuum	Others
	2 0 °C	Slightly	%					
Change control	<input type="checkbox"/> Yes		<input checked="" type="checkbox"/> No					
Motor	(This must be specified when a single axis module is used.)							
Quantity per 1 unit								
Plan to use with a prototype								
Quantity in mass production								

Specifications of ball screw

Screw shaft dia.	Thread direction	Axial clearance	Thread length	Preload
Lead	Number of circuit	Accuracy grade	Overall length	Required torque
Nut type	<input type="checkbox"/> Single <input type="checkbox"/> Double <input type="checkbox"/> Integral	Flange type	Installation direction	

Other requirements

<p style="font-style: italic;">Please calculate lifetime expectancy</p>	
KURODA sales office	Sales person

WARNING

FAILURE OR IMPROPER SELECTION OR IMPROPER USE OF THE PRODUCTS AND/OR SYSTEMS DESCRIBED HEREIN OR RELATED ITEMS CAN CAUSE DEATH, PERSONAL INJURY AND PROPERTY DAMAGE.

This document and other information from KURODA PRECISION INDUSTRIES LTD. and authorized distributors provide product and/or system options for further investigation by users having technical expertise. It is important that you analyze all aspects of your application, including consequences of any failure and review the information concerning the product or system in the current product catalog. Due to the variety of operating conditions and applications for these products or systems, the user, through its own analysis and testing, is solely responsible for making the final selection of the products and systems and assuring that all performance, safety and warning requirements of the application are met.

The products described herein, including without limitation, product features, specifications, designs, availability and pricing, are subject to change by KURODA PRECISION INDUSTRIES LTD. at any time without notice.

KURODA PRECISION INDUSTRIES LTD.

CAT. No. **KB1006-@**

Please Order From:
Clark & Osborne, LLP
6617 Ferguson Avenue
Indianapolis, IN 46220

Phone: (317) 255-5668
Fax: (317) 253-4486
sales@ClarkAndOsborne.com
www.ClarkAndOsborne.com