

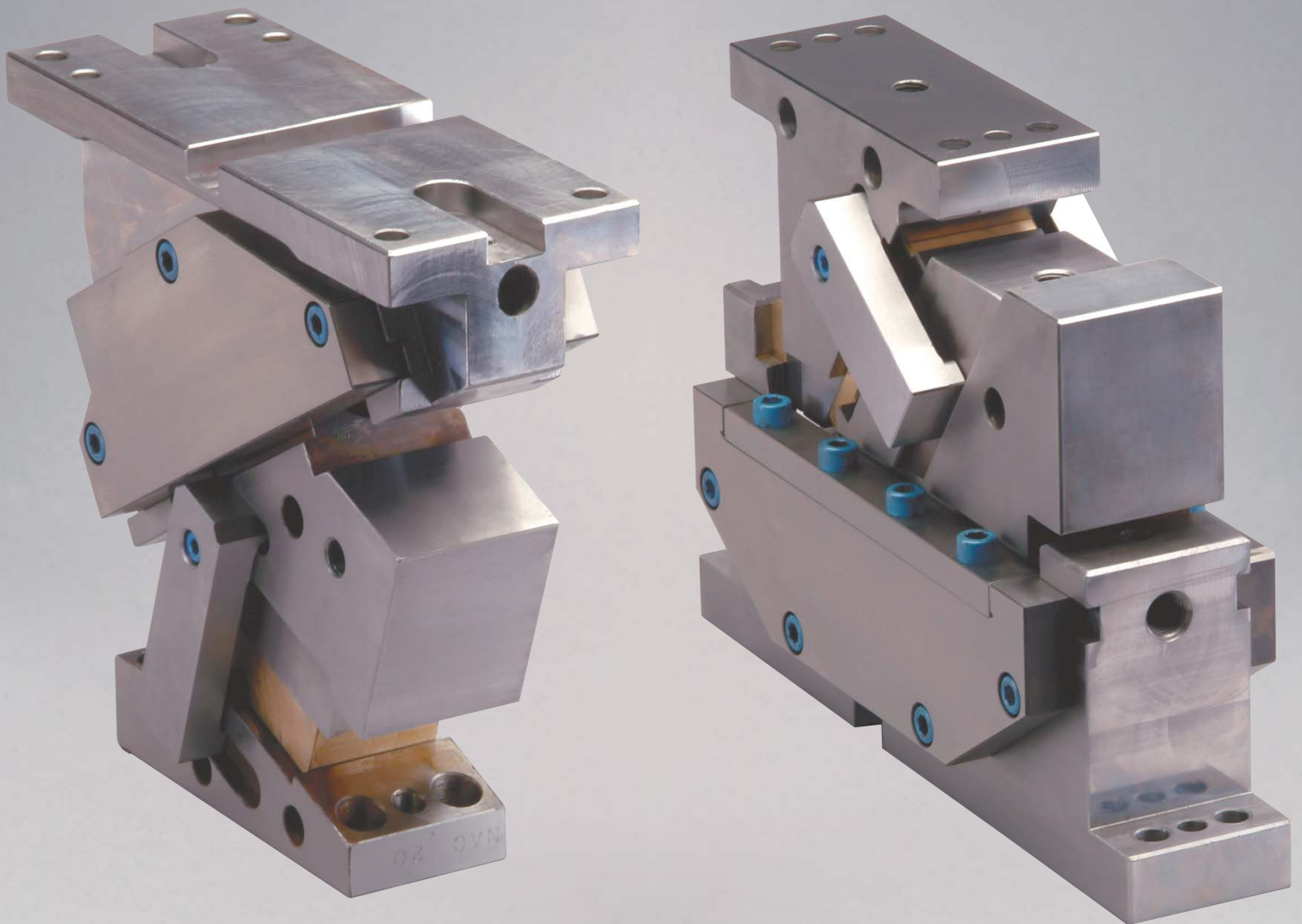

TRUSTED SOLUTIONS AND INNOVATION

AERIAL & DIE MOUNT CAMS CATALOG



Service We Deliver and Quality You Can Depend On

IEM is a leading manufacturer of die sets and die component products supplied globally to the parts forming industry. Backed by years of tool and die experience, quality and innovation are some of the reasons why our name is respected throughout the world. We have taken the lead role in creating and bringing new products to customers and helping them find solutions that improve their operations. Based on the capabilities **IEM** offers, we can help you to meet the demands of quick deliveries, technical support, quality products and competitive prices. **IEM** and its' broad distribution channels and direct sales personnel will assist you in any way to make your product a better and more profitable one.

Whether you purchase on-line or in person, you will receive the same reliable service **IEM** is known for. We understand the demanding schedules of die builders and production personnel and have developed efficient manufacturing processes to shorten product lead times as well as put inventory on our shelves so you can have it in your facility when you need it. Put the **IEM** network to work for you. We've got the service you've been looking for.

Included in our full line offering are both inch and metric size die sets and die components that are designed to numerous die standards including ISO, NAAMS, JIS and many large automotive and appliance manufacturers' standards. The complete product offering includes:

- Ball bearing and friction style die sets including custom and catalog sets
- Machined plate
- Guide posts & bushings
- ISO and JIS Die Springs
- In-die tapping units for both mechanical and hydraulic presses
- Formathane® Urethane springs, strippers, sheets, bars, rods and die cover film
- Diemakers' supplies such as pry bars, dowel pins, hoist rings, clamps and fasteners
- Standard and self-lubricating wear product including wear plate, wear strips, gibs, keeper plates and guide blocks
- Cam units, including Mini™, Aerial and Die Mount styles
- Accu-Bend™ Rotary Benders
- Standard and Ball lock punches and retainers
- Air presses
- Pad retainers
- Nitrogen gas springs



CONTENTS

	PAGE NUMBER
Cam Selection Matrix	2
General Information	3
NAAMS Standards Aerial Cams	
50 mm	4
75 mm	6
125 mm	8
150 mm	10
175 mm	12
200 mm	14
250 mm	16
300 mm	18
NAAMS Standards Die Mount Cams	
50 mm	20
75 mm	22
150 mm	24
200 mm	26
250 mm	28
300 mm	33
Long Reaching (Extra Travel) Die Mount Cams (LRD)	
When to Use a LRD Cam	33
75 mm	34
150 mm	36
200 mm	38
Calculation of Load and Stroke	40

Cam Selection Matrix

	NAAMS Standards								
	Gib™	Mini™	Long Reach Box (Extra Travel)	Standard Box	Max Power™ Box (MP)	Milfab®	NDM Die Mounts	NAC-Aerial	Long Reaching (Extra Travel) Die Mount
Inch		X	X	X		X			
Metric	X	X	X	X	X	X	X	X	X
Low profile	X					X			
Narrow width		X	X			X			
Short length		X		X	X	X			
Maximum slide travel			X						X
Maximum stripping force					X	X			
Nitrogen Return					X	X	X	X	X
Positive return	X					X	X	X	X
Maximum piercing force					X	X	X	X	X
Designed to NAAMS Standards							X	X	
Special Cam Designs Available	X	X	X	X	X	X	X	X	X

Items in the blue shaded area are included in this catalog.

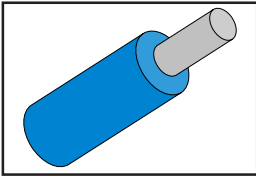

Nitrogen Return Option – Using nitrogen springs to replace the standard mechanical springs will provide more slide return force for applications involving heavier tooling mounted on the slide face. Individual return forces can be found on the specifications table for each size cam.

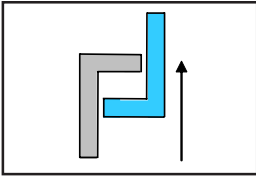

Positive Return – Included are mechanical return straps designed into the cam to pull the slide and tooling out of the part in case of a tooling jam. Positive return straps are designed to provide a positive return but are not designed to provide continuous stripping force.

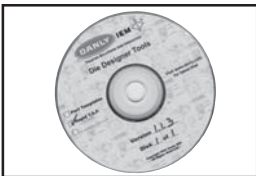

Electronic Templates Available – Each cam has Template or Model files saved for easy download into your die designs. The slide, body and driver are broken into three components for die movement simulation. The formats available are 2D/3D DWG, IGES, STEP, Parasolid, Catia, and Solidworks.

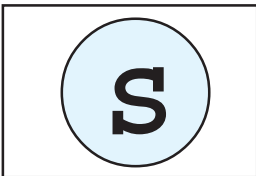

Special Cam Designs – We know there are sometimes when a standard cam doesn't fit into an application or is at the wrong angle. If you provide us with your application specifications, we will design and build a special cam for you.

Product Information

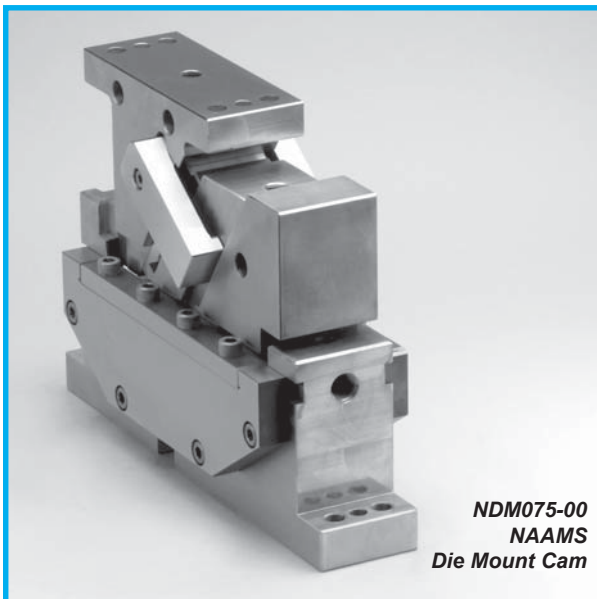
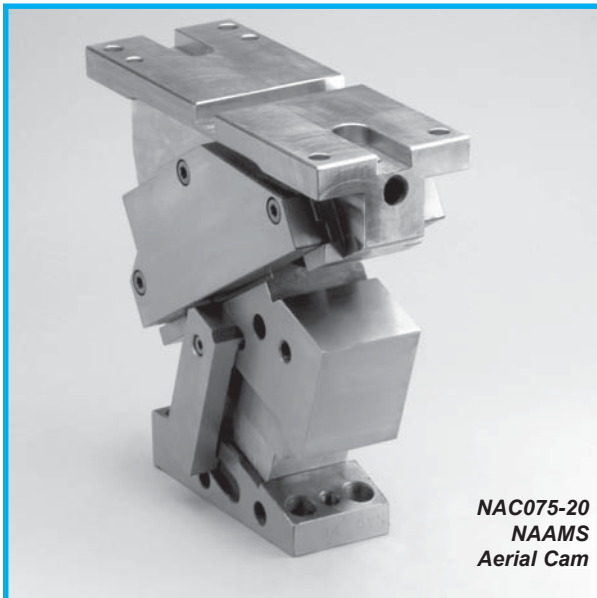

Product Features

Every NAAMS cam provides excellent performance and is designed with heavy-duty high volume production in mind.

- ◆ Self lubricating sliding surfaces provide maintenance free operation.
- ◆ Aluminum Bronze against steel wear surfaces is standard with an option of steel on steel wear surfaces.
- ◆ Slide accelerators are added to certain angles for quiet operation & reduced wear.
- ◆ Positive return(s) on the cam slide assures slide retraction and extra protection.
- ◆ Ease of setup with home position slide lockout capabilities.
- ◆ Rear spring access for ease of maintenance.
- ◆ Quick slide removal with top access keeper plate for all die mount cams.

Aerial Cam – 50 mm

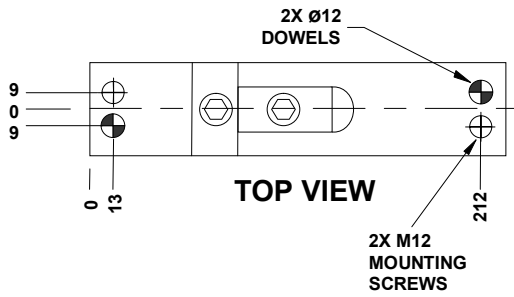

WORK ANGLE	Z
0 - 15°	147.5
20 - 60°	127.5

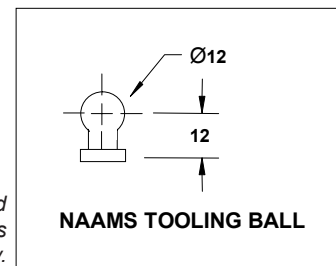
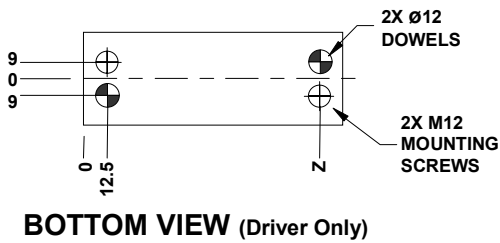
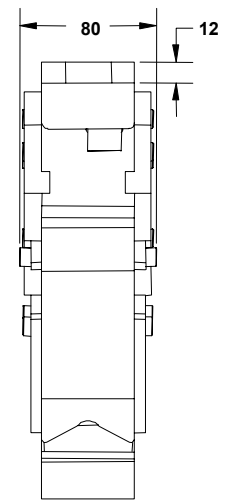
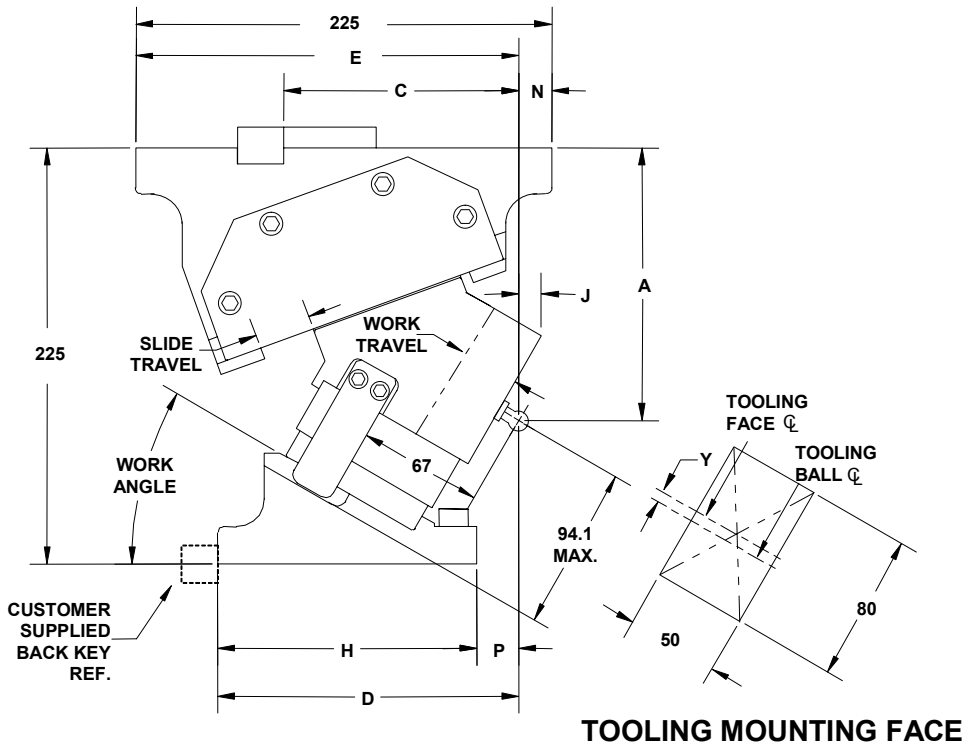
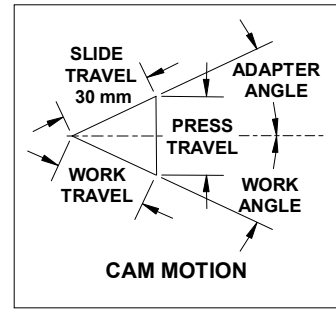

Tooling ball is not supplied with the cam and is a reference point only.

*Tooling ball located at "A" dimension per NAAMS.
 "Y" dimension represents the tooling ball from the slide centerline.
 Dowel holes undersized 0.2/0.3mm.
 All dimensions are for reference only.
 No tolerance is stated or implied.*

Ask Customer Service for design templates on our website or CD.
 Picture not representative of all angles.

Aerial Cam – 50 mm

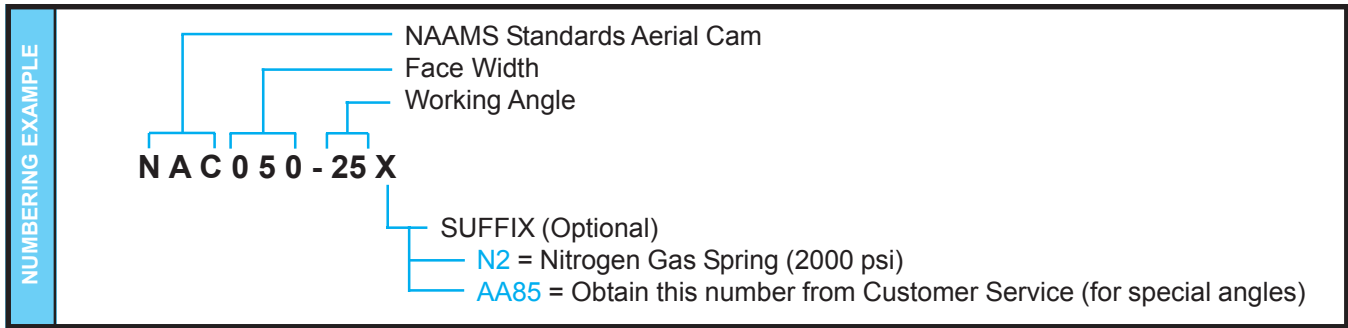

Part Number	NAAMS Number	Work Angle	Adapt Angle	Work Travel (mm)	A (mm)	C (mm)	D (mm)	E (mm)	H (mm)	J (mm)	N (mm)	P (mm)	Y (mm)
NAC050-00	C130500	0	50	19.3	120	155.5	150.5	241.9	160.0	-12.0	-16.9	-9.5	1.1
NAC050-05	C130505	5	45	21.3	125	149.5	153.0	237.5	160.0	-8.3	-12.5	-7.0	2.0
NAC050-10	C130510	10	40	23.3	130	145.0	160.1	231.0	160.0	-4.1	-6.0	0.1	4.4
NAC050-15	C130515	15	35	25.5	135	140.5	166.9	228.6	160.0	-0.4	-3.6	6.9	6.0
NAC050-20	C130520	20	30	27.7	140	134.5	151.9	220.3	140.0	5.1	4.7	11.9	7.4
NAC050-25	C130525	25	25	30.2	145	130.0	156.9	213.5	140.0	9.8	11.5	16.9	8.2
NAC050-30	C130530	30	20	32.9	150	125.5	163.1	205.6	140.0	14.1	19.4	23.1	7.7
NAC050-35	C130535	35	15	35.7	155	119.5	163.0	198.1	140.0	18.5	26.9	23.0	7.7
NAC050-40	C130540	40	10	38.9	160	115.0	167.0	188.0	140.0	22.1	37.0	27.0	6.7
NAC050-45	C130545	45	5	42.7	165	110.5	168.8	180.9	140.0	25.1	44.1	28.8	5.3
NAC050-50	C130550	50	0	47.1	170	106.0	171.0	174.5	140.0	27.7	50.5	31.0	4.0
NAC050-55	C130555	55	0	52.7	175	101.5	171.1	167.6	140.0	28.8	57.4	31.1	2.0
NAC050-60	C130560	60	0	60.4	180	98.5	174.3	162.8	140.0	28.1	62.2	34.3	-0.3

Max. Work Force (KN/Tons)	Slide Travel (mm)	Mechanical Spring Return Force	Nitrogen Spring Return Force ¹	Maximum Tooling Weight		Maximum Tooling Envelope ²		Approx. Cam Unit Weight (Kg/Lbs)
		Final (Kg/Lbs) [One Spring]	Final (Kg/Lbs) [One Spring]	Weight (Kg/Lbs) Mechanical Spring	Weight (Kg/Lbs) Nitrogen Spring	Protrusion (mm)	Tooling Overhang per side of Slide (mm)	
134/15	30	153/338	94/208	8/18	16/35	125	20	21/45

¹Optional nitrogen cylinders do not have a pre-load. Listed nitrogen ratings are at the end of their stroke.

²Exceeding the maximum tooling envelope will reduce cam performance and shorten the life of the cam.

$$\text{PRESS TRAVEL} = \text{Work Travel} \times \frac{\sin \left(\frac{\text{Adapter Angle} + \text{Work Angle}}{\cos (\text{Adapter Angle})} \right)}$$

Ask Customer Service for design templates on our website or CD.
Picture not representative of all angles.

All dimensions are for reference only.
No tolerance is stated or implied.

Aerial CAM – 75 mm

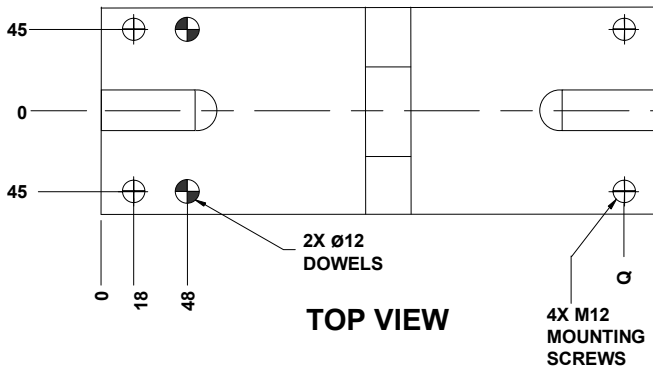

WORK ANGLE	Q	Z
0°	272	18.5
5°	282	18.5
10°	292	18.5
15°	287	18.5
20°	292	22.5
25°	282	22.5
30°	292	22.5
35°	287	22.5
40°	287	22.5
45°	287	22.5
50°	277	22.5
55°	277	22.5
60°	277	22.5

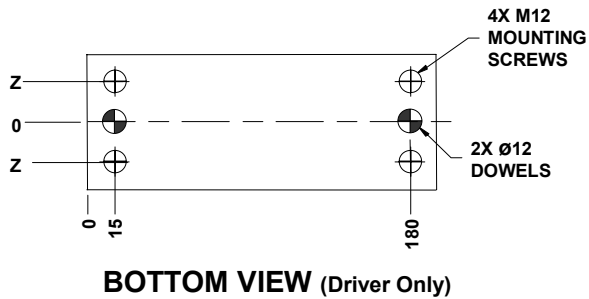
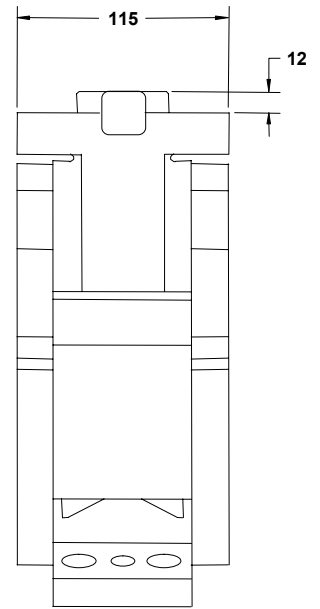
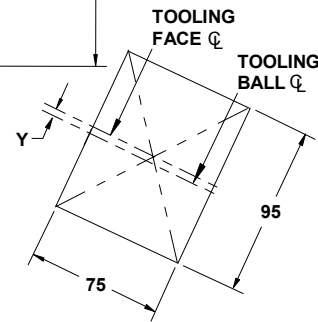
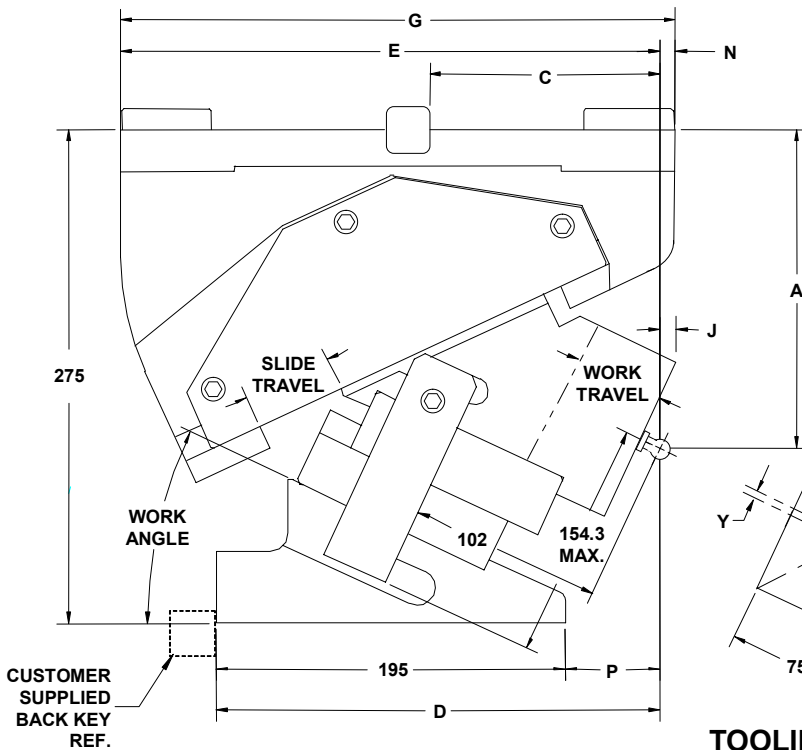
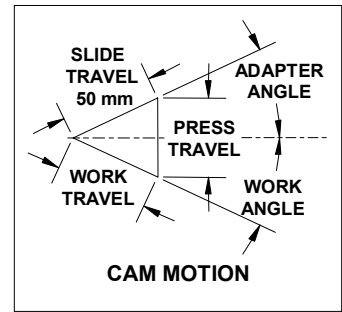

Tooling ball is not supplied with the cam and is a reference point only.

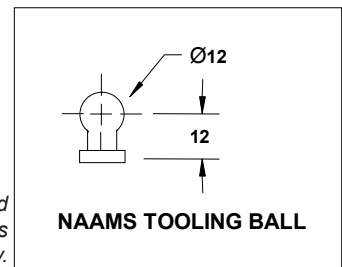

*Tooling ball located at "A" dimension per NAAMS.
 "Y" dimension represents the tooling ball from the slide centerline.
 Dowel holes undersized 0.2/0.3mm.
 All dimensions are for reference only.
 No tolerance is stated or implied.*

Ask Customer Service for design templates on our website or CD.
 Picture not representative of all angles.

Aerial CAM – 75 mm

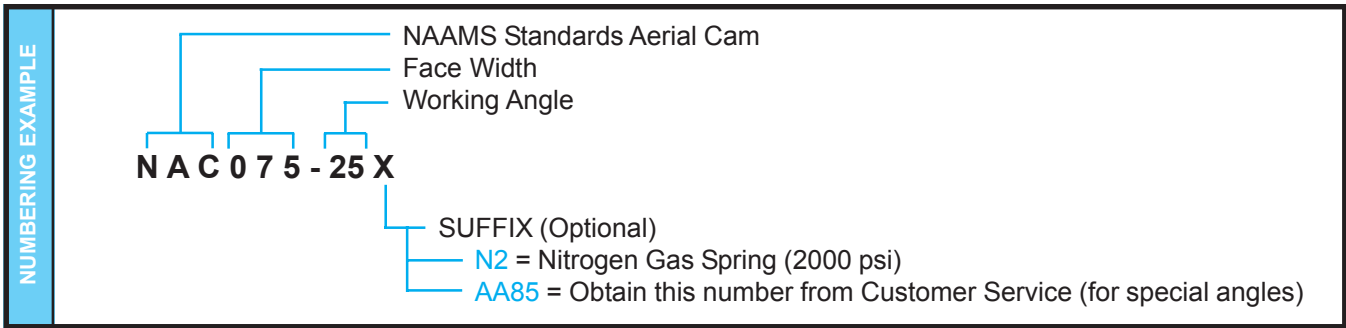

Part Number	NAAMS Number	Work Angle	Adapt Angle	Work Travel (mm)	A (mm)	C (mm)	D (mm)	E (mm)	G (mm)	J (mm)	N (mm)	P (mm)	Y (mm)
NAC075-00	C130700	0	50	32.1	155	180.0	210.1	330.0	290	-12.0	-40.0	15.1	15.0
NAC075-05	C130705	5	45	35.5	160	160.5	217.5	330.2	300	-6.6	-30.2	22.5	14.4
NAC075-10	C130710	10	40	38.9	165	153.0	224.7	330.4	310	-1.3	-20.4	29.7	13.2
NAC075-15	C130715	15	35	42.4	170	144.0	230.9	320.0	305	4.3	-15.0	35.9	13.9
NAC075-20	C130720	20	30	46.1	175	136.5	237.6	315.0	310	8.9	-5.0	42.6	11.5
NAC075-25	C130725	25	25	50.0	180	127.5	246.6	300.0	300	10.4	0.0	51.6	2.8
NAC075-30	C130730	30	20	54.3	185	120.0	254.0	300.0	310	12.6	10.0	59.0	-1.5
NAC075-35	C130735	35	15	59.0	190	112.5	261.8	285.0	305	13.6	20.0	66.8	-6.7
NAC075-40	C130740	40	10	64.3	195	105.0	270.4	275.0	305	12.9	30.0	75.4	-13.2
NAC075-45	C130745	45	5	70.4	200	99.0	274.9	265.0	305	15.1	40.0	79.9	-14.1
NAC075-50	C130750	50	0	77.8	205	93.0	278.6	263.6	295	17.2	31.4	83.6	-15.0
NAC075-55	C130755	55	0	87.2	210	72.0	267.5	240.9	295	33.8	54.1	72.5	2.2
NAC075-60	C130760	60	0	100.0	215	79.0	282.0	246.8	295	24.9	48.2	87.0	-11.8

Max. Work Force (KN/Tons)	Slide Travel (mm)	Mechanical Spring Return Force	Nitrogen Spring Return Force ¹	Maximum Tooling Weight		Maximum Tooling Envelope ²		Approx. Cam Unit Weight (Kg/Lbs)
		Final (Kg/Lbs) [One Spring]	Final (Kg/Lbs) [One Spring]	Weight (Kg/Lbs) Mechanical Spring	Weight (Kg/Lbs) Nitrogen Spring	Protrusion (mm)	Tooling Overhang per side of Slide (mm)	
134/15	50	220/485	316/697	12/26	24/53	140	20	46/100

¹Optional nitrogen cylinders do not have a pre-load. Listed nitrogen ratings are at the end of their stroke.

²Exceeding the maximum tooling envelope will reduce cam performance and shorten the life of the cam.

$$\text{PRESS TRAVEL} = \text{Work Travel} \times \frac{\sin \left(\frac{\text{Adapter Angle} + \text{Work Angle}}{\cos (\text{Adapter Angle})} \right)}$$

Ask Customer Service for design templates on our website or CD.
Picture not representative of all angles.

All dimensions are for reference only.
No tolerance is stated or implied.

Aerial Cam – 125 mm

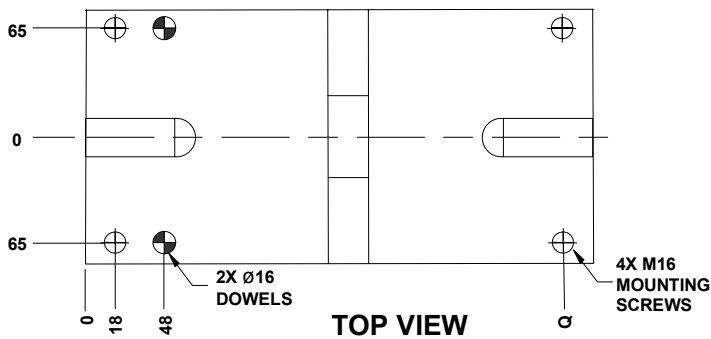

WORK ANGLE	Q
0°	272
5°	282
10°	292
15°	287
20°	292
25°	282
30°	292
35°	287
40°	287
45°	287
50°	277
55°	277
60°	277

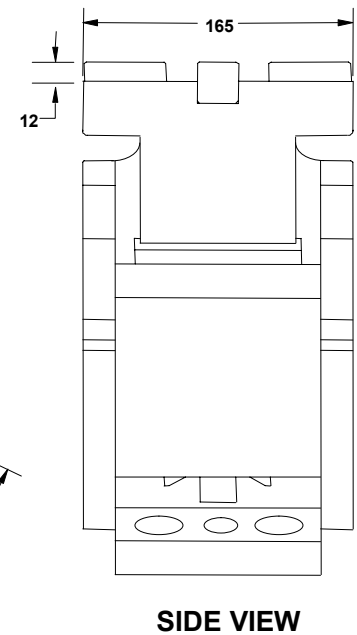
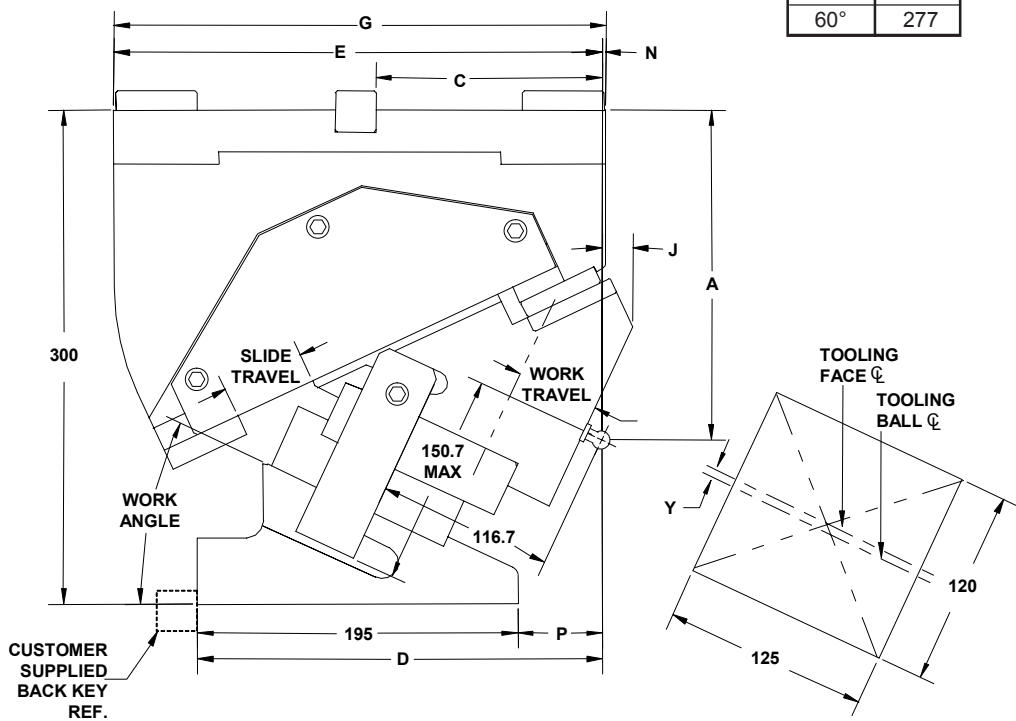
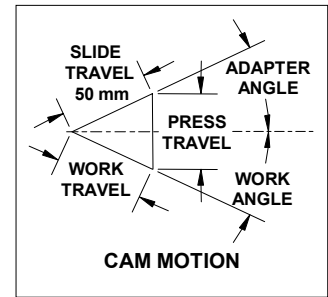

TOOLING MOUNTING FACE

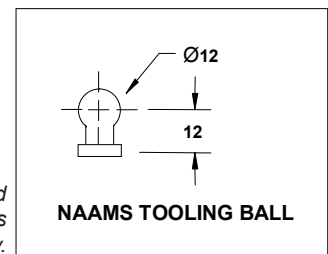
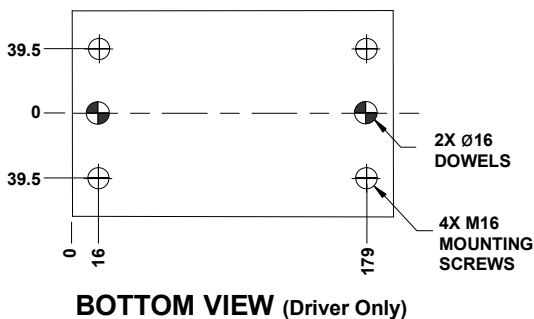

Tooling ball is not supplied with the cam and is a reference point only.

Tooling ball located at "A" dimension per NAAMS.
"Y" dimension represents the tooling ball from the slide centerline.
Dowel holes undersized 0.2/0.3mm.
All dimensions are for reference only.
No tolerance is stated or implied.

Ask Customer Service for design templates on our website or CD.
Picture not representative of all angles.

Aerial Cam – 125 mm

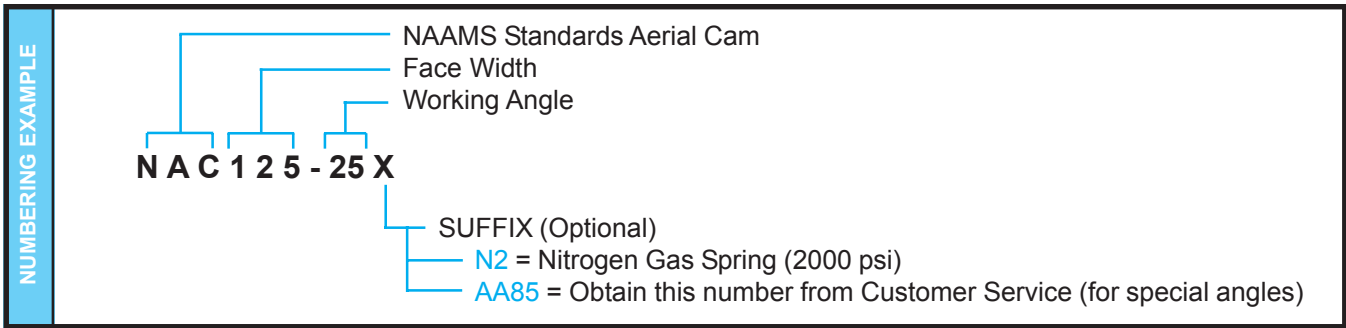

Part Number	NAAMS Number	Work Angle	Adapt Angle	Work Travel (mm)	A (mm)	C (mm)	D (mm)	E (mm)	G (mm)	J (mm)	N (mm)	P (mm)	Y (mm)
NAC125-00	C131200	0	50	32.1	170	180.5	210.1	330.0	290	-12.0	-40.0	15.1	15.0
NAC125-05	C131205	5	45	35.5	175	173.0	218.2	330.0	300	-5.5	-30.0	23.2	14.4
NAC125-10	C131210	10	40	38.9	180	165.5	226.0	330.0	310	0.9	-20.0	31.0	13.1
NAC125-15	C131215	15	35	42.4	185	156.5	233.6	320.0	305	6.8	-15.0	38.6	11.1
NAC125-20	C131230	20	30	46.1	190	149.0	241.2	315.0	310	12.1	-5.0	46.2	8.3
NAC125-25	C131225	25	25	50.0	195	140.0	248.9	300.0	300	16.5	0.0	53.9	4.8
NAC125-30	C131230	30	20	54.3	205	132.5	254.0	300.0	310	22.6	10.0	59.0	6.0
NAC125-35	C131235	35	15	59.0	215	125.0	258.3	285.0	305	28.5	20.0	63.3	6.9
NAC125-40	C131240	40	10	64.3	225	117.5	262.0	275.0	305	34.1	30.0	67.0	7.4
NAC125-45	C131245	45	5	70.4	235	111.5	264.9	265.0	305	39.3	40.0	69.9	7.5
NAC125-50	C131250	50	0	77.8	245	105.5	267.3	252.3	295	43.9	42.7	72.3	7.3
NAC125-55	C131255	55	0	87.2	255	120.0	289.8	266.8	295	34.1	28.2	94.8	-10.0
NAC125-60	C131260	60	0	100.0	265	113.0	286.4	259.7	295	45.4	35.3	91.4	-0.7

Max. Work Force (KN/Tons)	Slide Travel (mm)	Mechanical Spring Return Force (Kg/Lbs) [One Spring]	Nitrogen Spring Return Force ¹ (Kg/Lbs) [One Spring]	Maximum Tooling Weight		Maximum Tooling Envelope ²		Approx. Cam Unit Weight (Kg/Lbs)
				Weight (Kg/Lbs) Mechanical Spring	Weight (Kg/Lbs) Nitrogen Spring	Protrusion (mm)	Tooling Overhang per side of Slide (mm)	
178/20	50	220/485	316/697	20/44	40/88	150	20	77/170

¹Optional nitrogen cylinders do not have a pre-load. Listed nitrogen ratings are at the end of their stroke.

²Exceeding the maximum tooling envelope will reduce cam performance and shorten the life of the cam.

- ◆ Accelerator included (0° – 45°)

$$\text{PRESS TRAVEL} = \text{Work Travel} \times \frac{\sin \left(\frac{\text{Adapter Angle} + \text{Work Angle}}{\cos (\text{Adapter Angle})} \right)}$$

Ask Customer Service for design templates on our website or CD.
Picture not representative of all angles.

All dimensions are for reference only.
No tolerance is stated or implied.

Aerial Cam – 150 mm

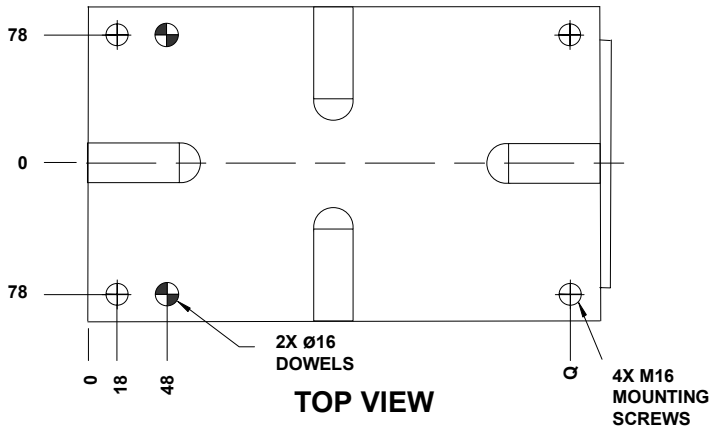

WORK ANGLE	Q
0°	272
5°	282
10°	292
15°	287
20°	292
25°	282
30°	292
35°	287
40°	287
45°	287
50°	277
55°	277
60°	277

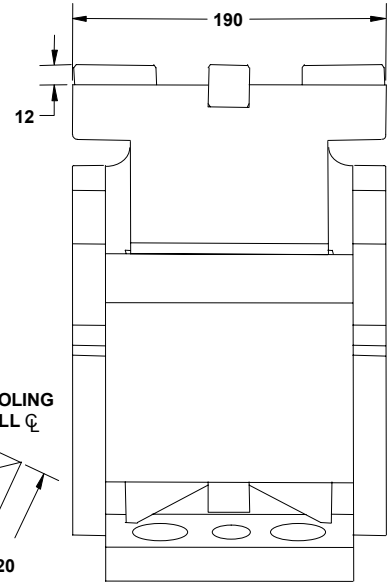
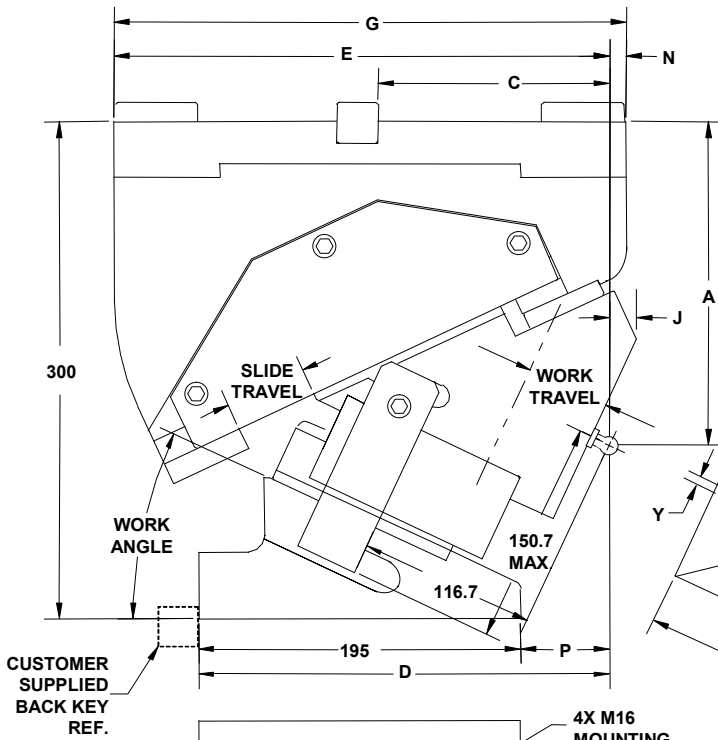
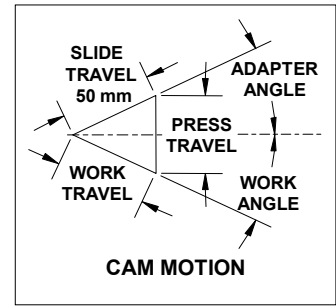

TOOLING MOUNTING FACE

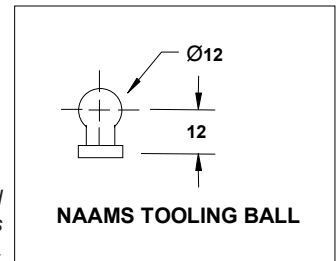
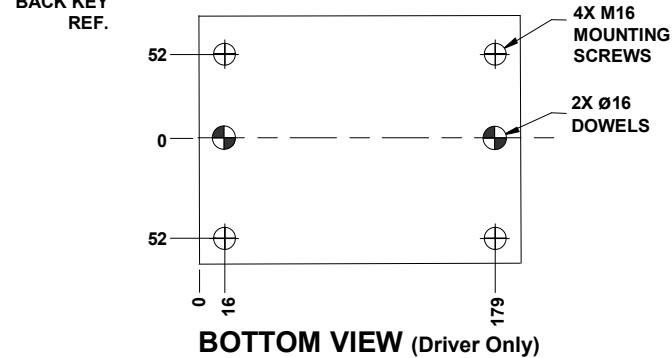

Tooling ball is not supplied with the cam and is a reference point only.

*Tooling ball located at "A" dimension per NAAMS.
 "Y" dimension represents the tooling ball from the slide centerline.
 Dowel holes undersized 0.2/0.3mm.
 All dimensions are for reference only.
 No tolerance is stated or implied.*

Ask Customer Service for design templates on our website or CD.
 Picture not representative of all angles.

Aerial Cam – 150 mm

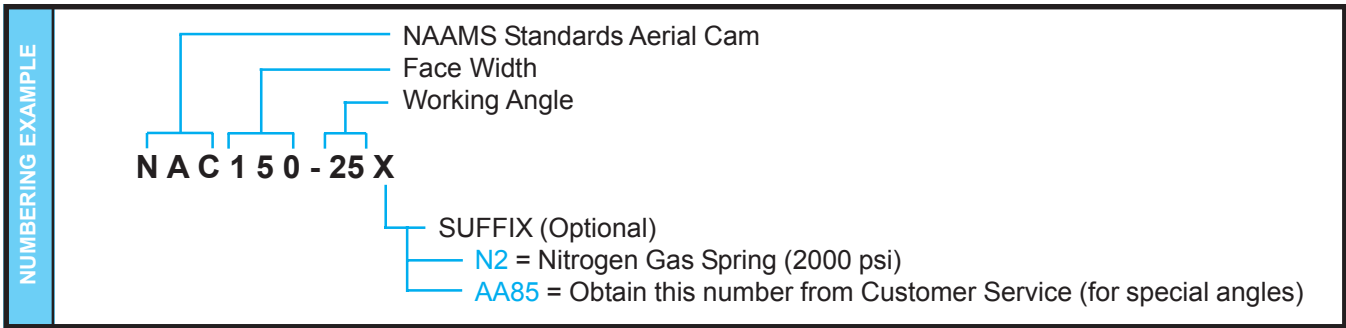

Part Number	NAAMS Number	Work Angle	Adapt Angle	Work Travel (mm)	A (mm)	C (mm)	D (mm)	E (mm)	G (mm)	J (mm)	N (mm)	P (mm)	Y (mm)
NAC150-00	C131500	0	50	32.1	170	180.5	210.1	330.0	290	-12.0	-40.0	15.1	15.0
NAC150-05	C131505	5	45	35.5	175	173.0	218.2	330.0	300	-5.5	-30.0	23.2	14.4
NAC150-10	C131510	10	40	38.9	180	165.5	226.0	330.0	310	0.9	-20.0	31.0	13.1
NAC150-15	C131515	15	35	42.4	185	156.5	233.6	320.0	305	6.8	-15.0	38.6	11.1
NAC150-20	C131520	20	30	46.1	190	149.0	241.2	315.0	310	12.1	-5.0	46.2	8.3
NAC150-25	C131525	25	25	50.0	195	140.0	248.9	300.0	300	16.5	0.0	53.9	4.8
NAC150-30	C131530	30	20	54.3	205	132.5	254.0	300.0	310	22.6	10.0	59.0	5.7
NAC150-35	C131535	35	15	59.0	215	125.0	258.3	285.0	305	28.5	20.0	63.3	6.9
NAC150-40	C131540	40	10	64.3	225	117.5	262.0	275.0	305	34.1	30.0	67.0	7.4
NAC150-45	C131545	45	5	70.4	235	111.5	264.9	265.0	305	39.3	40.0	69.9	7.5
NAC150-50	C131550	50	0	77.8	245	105.5	267.3	252.3	295	43.9	42.7	72.3	7.3
NAC150-55	C131555	55	0	87.2	255	120.0	289.8	266.8	295	34.1	28.2	94.8	-10.0
NAC150-60	C131560	60	0	100.0	265	113.0	289.3	259.7	295	45.4	35.3	94.3	-0.7

Max. Work Force (KN/Tons)	Slide Travel (mm)	Mechanical Spring Return Force (Kg/Lbs) [Two Springs]	Nitrogen Spring Return Force ¹ (Kg/Lbs) [Two Springs]	Maximum Tooling Weight		Maximum Tooling Envelope ²		Approx. Cam Unit Weight (Kg/Lbs)
				Weight (Kg/Lbs) Mechanical Spring	Weight (Kg/Lbs) Nitrogen Spring	Protrusion (mm)	Tooling Overhang per side of Slide (mm)	
223/25	50	440/970	632/1394	20/44	40/88	150	20	96/210

¹Optional nitrogen cylinders do not have a pre-load. Listed nitrogen ratings are at the end of their stroke.

²Exceeding the maximum tooling envelope will reduce cam performance and shorten the life of the cam.

- ◆ Accelerator included (0° – 45°)

$$\text{PRESS TRAVEL} = \text{Work Travel} \times \frac{\sin \left(\frac{\text{Adapter Angle} + \text{Work Angle}}{\cos (\text{Adapter Angle})} \right)}$$

Ask Customer Service for design templates on our website or CD.
Picture not representative of all angles.

All dimensions are for reference only.
No tolerance is stated or implied.

Aerial Cam – 175 mm

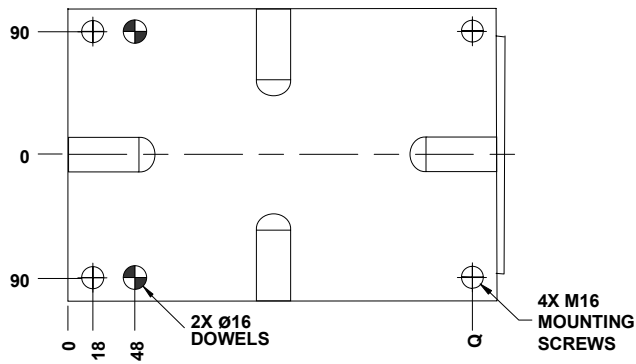

TOP VIEW

WORK ANGLE	Q
0°	272
5°	282
10°	292
15°	287
20°	292
25°	282
30°	292
35°	287
40°	287
45°	287
50°	277
55°	277
60°	277

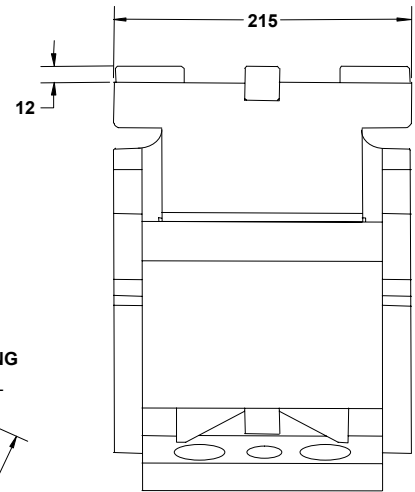
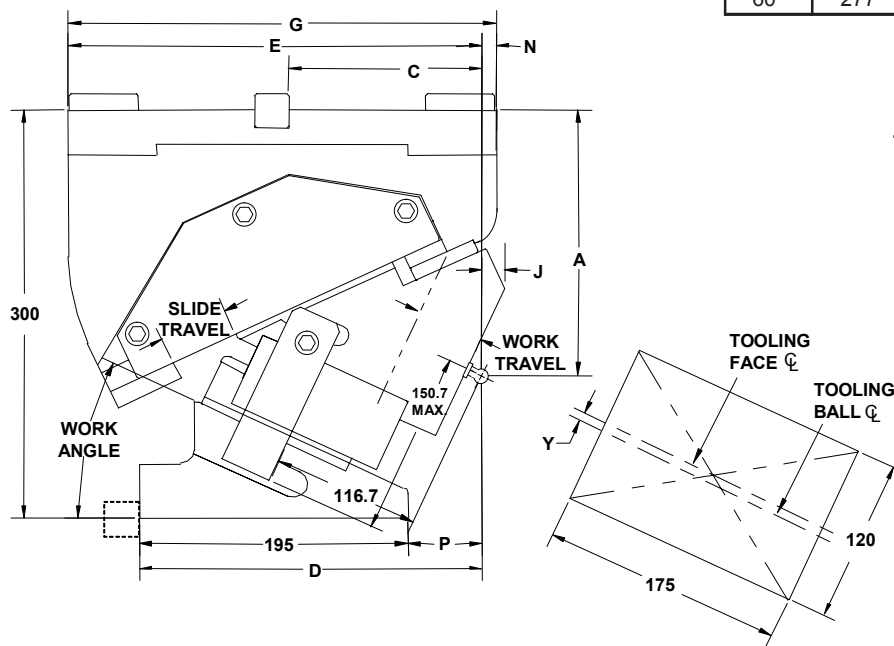
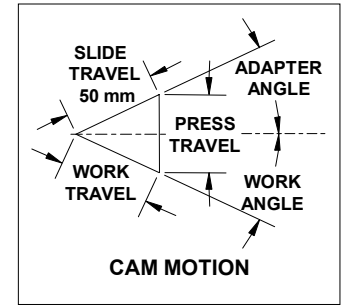

TOOLING MOUNTING FACE

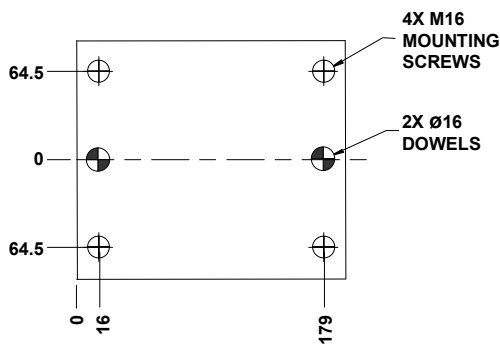

BOTTOM VIEW (Driver Only)

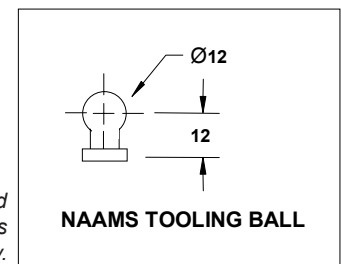

Tooling ball is not supplied with the cam and is a reference point only.

Tooling ball located at "A" dimension per NAAMS.
"Y" dimension represents the tooling ball from the slide centerline.
Dowel holes undersized 0.2/0.3mm.
All dimensions are for reference only.
No tolerance is stated or implied.

Ask Customer Service for design templates on our website or CD.
Picture not representative of all angles.

Aerial Cam – 175 mm

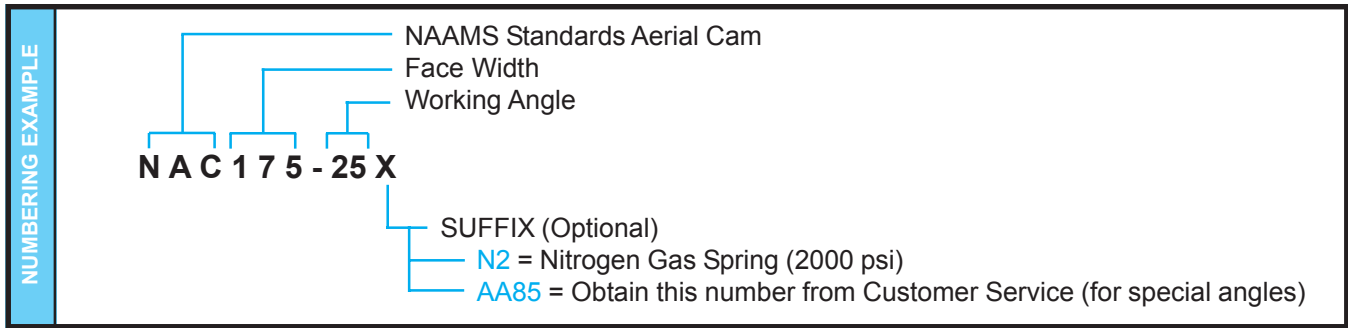

Part Number	NAAMS Number	Work Angle	Adapt Angle	Work Travel (mm)	A (mm)	C (mm)	D (mm)	E (mm)	G (mm)	J (mm)	N (mm)	P (mm)	Y (mm)
NAC175-00	C131700	0	50	32.1	170	180.5	210.1	330	290	-12.0	-40.0	15.1	15.0
NAC175-05	C131705	5	45	35.5	175	173.0	218.2	330	300	-5.5	-30.0	23.2	14.4
NAC175-10	C131710	10	40	38.9	180	165.5	226.0	330	310	0.9	-20.0	31.0	13.1
NAC175-15	C131715	15	35	42.4	185	156.5	233.6	320	305	6.8	-15.0	38.6	11.1
NAC175-20	C131720	20	30	46.1	190	149.0	241.2	315	310	12.1	-5.0	46.2	8.3
NAC175-25	C131725	25	25	50.0	195	140.0	248.9	300	300	16.5	0.0	53.9	4.8
NAC175-30	C131730	30	20	54.3	205	132.5	254.0	300	310	22.6	10.0	59.0	6.0
NAC175-35	C131735	35	15	59.0	215	125.0	258.3	285	305	28.6	20.0	63.3	6.9
NAC175-40	C131740	40	10	64.3	225	117.5	262.0	275	305	34.1	30.0	67.0	7.4
NAC175-45	C131745	45	5	70.4	235	111.5	264.9	265	305	39.3	40.0	69.9	7.5
NAC175-50	C131750	50	0	77.8	245	105.5	267.3	252.3	295	43.9	42.7	72.3	7.3
NAC175-55	C131755	55	0	87.2	255	120.0	289.9	266.8	295	34.1	28.2	94.9	-10.0
NAC175-60	C131760	60	0	100.0	265	113.0	289.3	259.7	295	45.4	35.3	94.3	-0.7

Max. Work Force (KN/Tons)	Slide Travel (mm)	Mechanical Spring Return Force (Kg/Lbs) [Two Springs]	Nitrogen Spring Return Force ¹ (Kg/Lbs) [Two Springs]	Maximum Tooling Weight		Maximum Tooling Envelope ²		Approx. Cam Unit Weight (Kg/Lbs)
				Weight (Kg/Lbs) Mechanical Spring	Weight (Kg/Lbs) Nitrogen Spring	Protrusion (mm)	Tooling Overhang per side of Slide (mm)	
267/30	50	440/970	632/1394	32/71	64/141	175	30	105/230

¹Optional nitrogen cylinders do not have a pre-load. Listed nitrogen ratings are at the end of their stroke.

²Exceeding the maximum tooling envelope will reduce cam performance and shorten the life of the cam.

◆ Accelerator included (0° – 45°)

$$\text{PRESS TRAVEL} = \text{Work Travel} \times \frac{\sin \left(\frac{\text{Adapter Angle} + \text{Work Angle}}{\cos (\text{Adapter Angle})} \right)}$$

Ask Customer Service for design templates on our website or CD.
Picture not representative of all angles.

All dimensions are for reference only.
No tolerance is stated or implied.

Aerial Cam – 200 mm

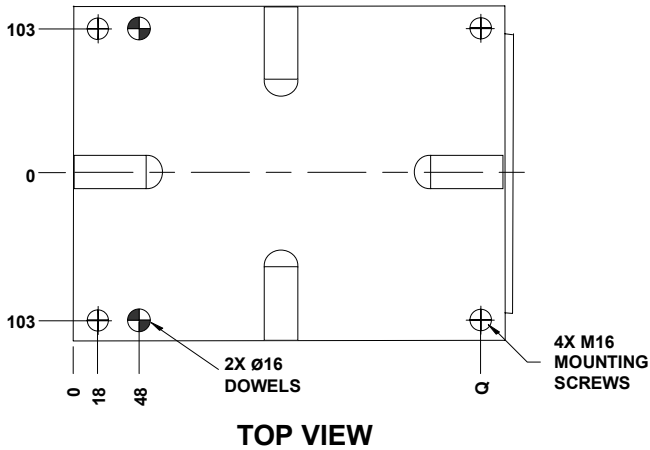

WORK ANGLE	Q
0°	272
5°	282
10°	292
15°	287
20°	292
25°	282
30°	292
35°	287
40°	287
45°	287
50°	277
55°	277
60°	277

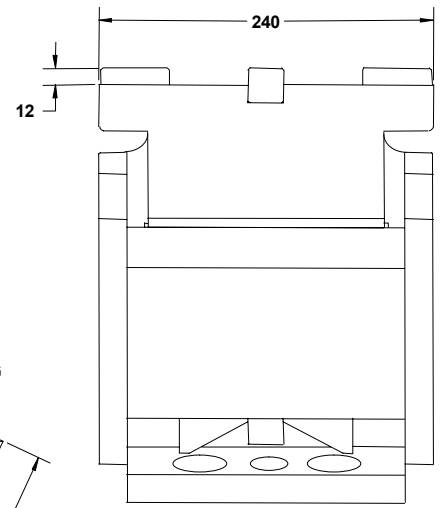
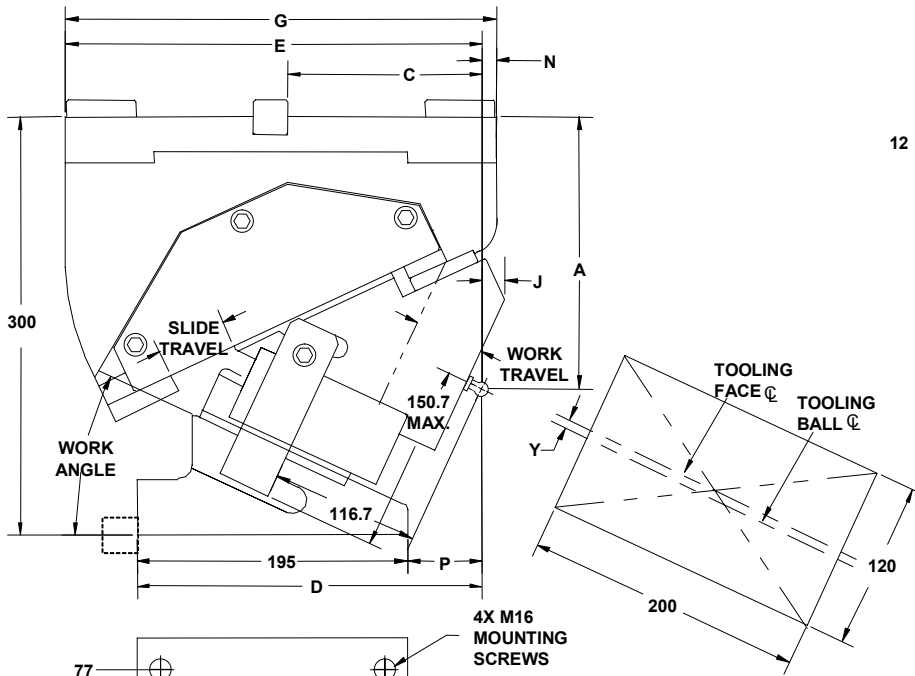
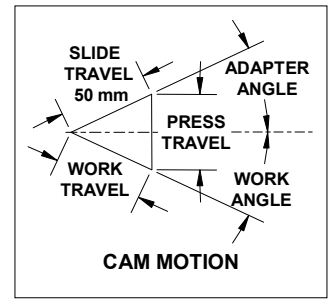

SIDE VIEW

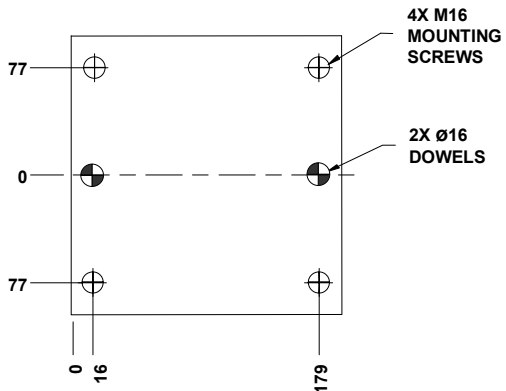

TOOLING MOUNTING FACE

BOTTOM VIEW (Driver Only)

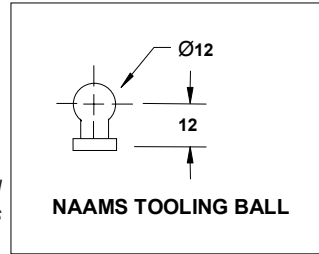

Tooling ball is not supplied with the cam and is a reference point only.

*Tooling ball located at "A" dimension per NAAMS.
"Y" dimension represents the tooling ball from the slide centerline.
Dowel holes undersized 0.2/0.3mm.
All dimensions are for reference only.
No tolerance is stated or implied.*

Ask Customer Service for design templates on our website or CD.
Picture not representative of all angles.

Aerial Cam – 200 mm

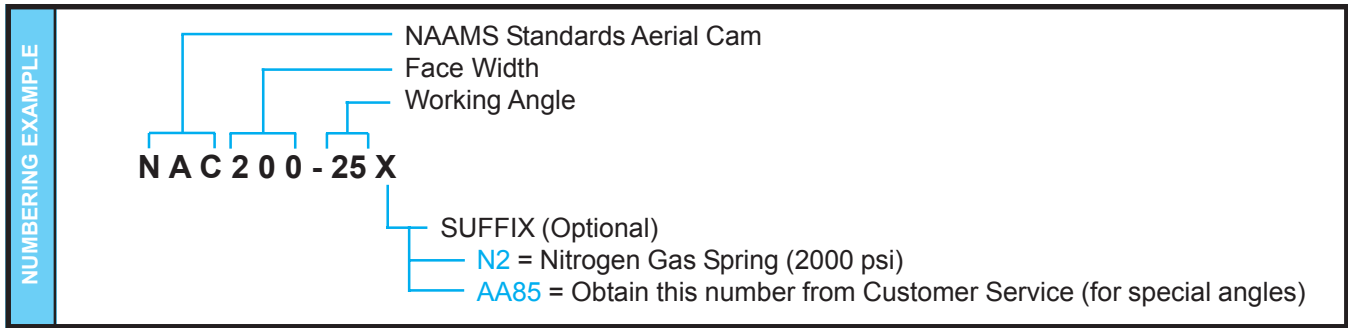

Part Number	NAAMS Number	Work Angle	Adapt Angle	Work Travel (mm)	A (mm)	C (mm)	D (mm)	E (mm)	G (mm)	J (mm)	N (mm)	P (mm)	Y (mm)
NAC200-00	C132000	0	50	32.1	170	180.5	210.1	330	290	-12.0	-40.0	15.1	15.0
NAC200-05	C132005	5	45	35.5	175	173.0	218.2	330	300	-5.5	-30.0	23.2	14.4
NAC200-10	C132010	10	40	38.9	180	165.5	226.0	330	310	0.9	-20.0	31.0	13.1
NAC200-15	C132015	15	35	42.4	185	156.5	233.6	320	305	6.8	-15.0	38.6	11.1
NAC200-20	C132020	20	30	46.1	190	149.0	241.2	315	310	12.1	-5.0	46.2	8.3
NAC200-25	C132025	25	25	50.0	195	140.0	248.9	300	300	16.5	0.0	53.9	4.8
NAC200-30	C132030	30	20	54.3	205	132.5	254.0	300	310	22.6	10.0	59.0	6.0
NAC200-35	C132035	35	15	59.0	215	125.0	258.3	285	305	28.6	20.0	63.3	6.9
NAC200-40	C132040	40	10	64.3	225	117.5	262.0	275	305	34.1	30.0	67.0	7.4
NAC200-45	C132045	45	5	70.4	235	111.5	264.9	265	305	39.3	40.0	69.9	7.5
NAC200-50	C132050	50	0	77.8	245	105.5	267.3	252.3	295	43.9	42.7	72.3	7.3
NAC200-55	C132055	55	0	87.2	255	120.0	289.9	266.8	295	34.1	28.2	94.9	-10.0
NAC200-60	C132060	60	0	100.0	265	113.0	289.3	259.7	295	45.4	35.3	94.3	-0.7

Max. Work Force (KN/Tons)	Slide Travel (mm)	Mechanical Spring Return Force	Nitrogen Spring Return Force ¹	# Optional Nitrogen Cylinder Pockets ²	Return Force per Nitrogen Spring (Kg/Lbs)	Maximum Tooling Weight		Maximum Tooling Envelope ³		Approx. Cam Unit Weight (Kg/Lbs)
		Final (Kg/Lbs) [Three Springs]	Final (Kg/Lbs) [Two Springs]			Weight (Kg/Lbs) Mechanical Spring	Weight (Kg/Lbs) Nitrogen Spring	Protrusion (mm)	Tooling Overhang per side of Slide (mm)	
312/35	50	660/1455	632/1394	1	316/697	32/71	64/141	175	30	127/280

¹Nitrogen cylinders do not have a pre-load. Listed nitrogen ratings are at the end of their stroke.

²Three spring pockets built into the cam, two nitrogen springs supplied with nitrogen spring configuration. Spring return calculated based on the standard spring quantity. Customer can add an additional spring for more return force.

³Exceeding the maximum tooling envelope will reduce cam performance and shorten the life of the cam.

- ◆ Accelerator included (0° – 45°)

$$\text{PRESS TRAVEL} = \text{Work Travel} \times \frac{\sin \left(\frac{\text{Adapter Angle} + \text{Work Angle}}{\cos (\text{Adapter Angle})} \right)}$$

Ask Customer Service for design templates on our website or CD.
Picture not representative of all angles.

All dimensions are for reference only.
No tolerance is stated or implied.

Aerial Cam – 250 mm

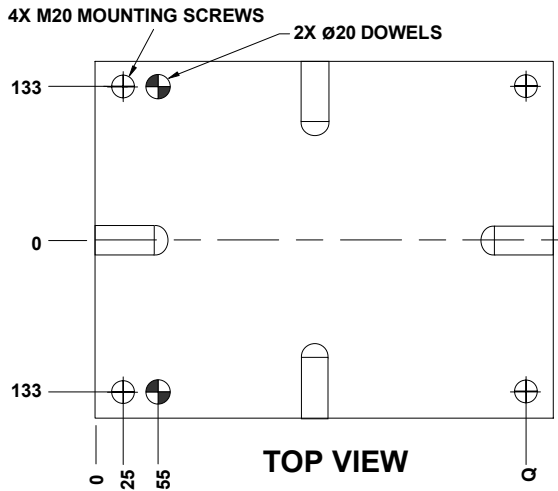

WORK ANGLE	Q	T	U
0°	320	170	210
5°	335	170	210
10°	345	170	210
15°	355	170	210
20°	370	170	210
25°	375	160	200
30°	375	145	185
35°	375	145	185
40°	375	135	175
45°	375	130	170
50°	350	135	175
55°	350	135	175
60°	350	135	175

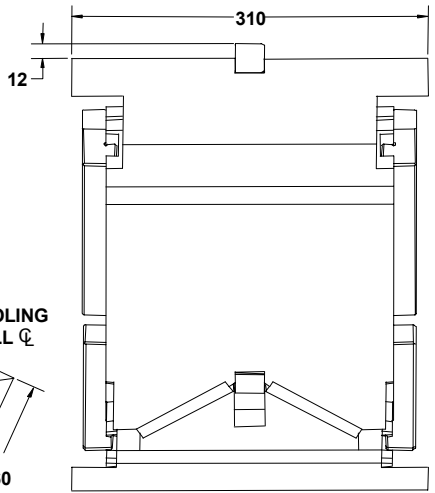
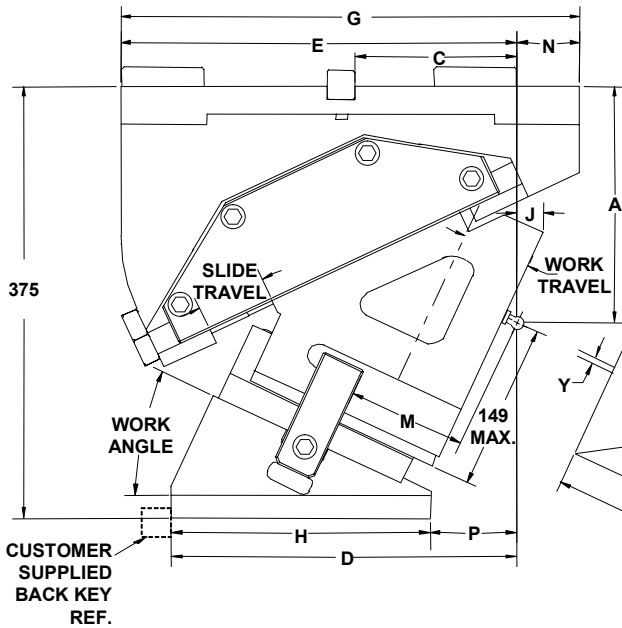
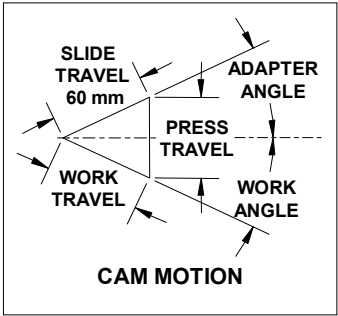

TOOLING MOUNTING FACE

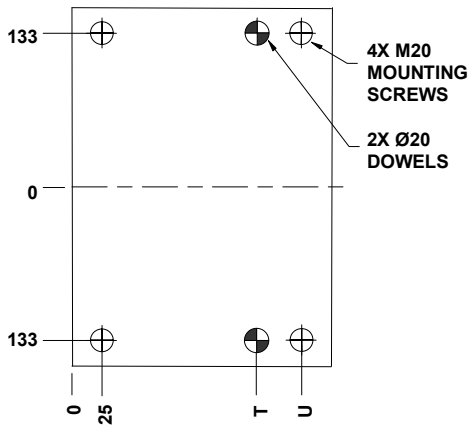

BOTTOM VIEW (Driver Only)

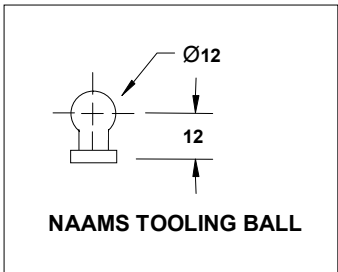

Tooling ball is not supplied with the cam and is a reference point only.

*Tooling ball located at "A" dimension per NAAMS.
 "Y" dimension represents the tooling ball from the slide centerline.
 Dowel holes undersized 0.2/0.3mm.
 All dimensions are for reference only.
 No tolerance is stated or implied.*

Ask Customer Service for design templates on our website or CD.
 Picture not representative of all angles.

Aerial Cam – 250 mm

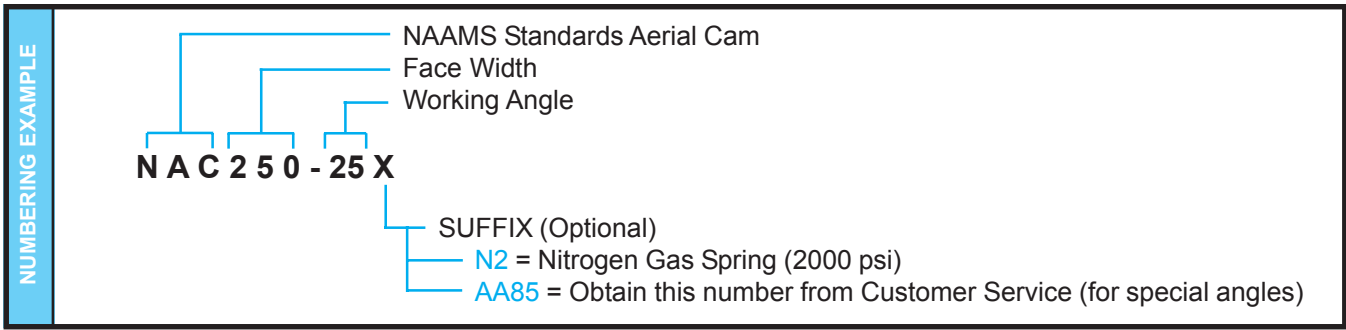

Part Number	NAAMS Number	Work Angle	Adapt. Angle	Work Travel (mm)	A (mm)	C (mm)	D (mm)	E (mm)	G (mm)	H (mm)	J (mm)	M (mm)	N (mm)	P (mm)	Y (mm)
NAC250-00	C132500	0	50	38.6	180.0	193.0	242.0	345.0	345	235	-12.0	103.0	0.0	7.0	14.1
NAC250-05	C132505	5	45	42.6	185.0	182.5	255.7	350.0	360	235	-4.1	103.0	10.0	20.7	10.7
NAC250-10	C132510	10	40	46.7	190.0	172.0	269.8	350.0	370	235	3.1	103.0	20.0	34.8	6.0
NAC250-15	C132515	15	35	50.9	195.0	161.5	283.3	350.0	380	235	10.5	103.0	30.0	48.3	5.2
NAC250-20	C132520	20	30	55.3	200.0	151.0	296.8	345.0	395	235	17.2	103.0	50.0	61.8	3.1
NAC250-25	C132525	25	25	60.0	205.0	140.5	300.6	345.0	400	225	22.8	103.0	55.0	75.6	-0.3
NAC250-30	C132530	30	20	65.1	215.0	130.0	297.0	335.0	400	210	29.9	103.0	65.0	87.0	0.5
NAC250-35	C132535	35	15	70.8	225.0	121.0	308.1	320.0	400	210	36.2	103.0	80.0	98.1	0.2
NAC250-40	C132540	40	10	77.1	235.0	112.0	309.1	315.0	400	200	41.3	103.0	85.0	109.1	-1.4
NAC250-45	C132545	45	5	84.5	245.0	103.0	315.3	310.0	400	195	45.0	103.0	90.0	120.3	-4.4
NAC250-50	C132550	50	0	93.3	265.0	94.0	320.1	289.8	375	200	58.5	103.0	85.2	120.1	6.5
NAC250-55	C132555	55	0	104.6	285.0	86.5	325.2	277.5	375	200	68.2	108.0	97.5	125.2	11.6
NAC250-60	C132560	60	0	120.0	300.0	79.0	326.9	263.0	375	200	76.3	108.0	112.0	126.9	15.0

Max. Work Force	Slide Travel	Mechanical Spring Return Force	Nitrogen Spring Return Force ¹	# Optional Nitrogen Cylinder Pockets ²	Return Force per Nitrogen Spring	Maximum Tooling Weight		Maximum Tooling Envelope ³		Approx. Cam Unit Weight
(KN/Tons)	(mm)	Final (Kg/Lbs) [Three Springs]	Final (Kg/Lbs) [Two Springs]		Final (Kg/Lbs)	Weight (Kg/Lbs) Mechanical Spring	Weight (Kg/Lbs) Nitrogen Spring	Protrusion (mm)	Tooling Overhang per side of Slide (mm)	(Kg/Lbs)
356/40	60	685/1512	640/1410	1	320/705	65/143	130/287	200	40	200/440

¹Nitrogen cylinders do not have a pre-load. Listed nitrogen ratings are at the end of their stroke.

²Three spring pockets built into the cam, two nitrogen springs supplied with nitrogen spring configuration. Spring return calculated based on the standard spring quantity. Customer can add an additional spring for more return force.

³Exceeding the maximum tooling envelope will reduce cam performance and shorten the life of the cam.

- ◆ Accelerator included (0° – 45°)

$$\text{PRESS TRAVEL} = \text{Work Travel} \times \frac{\sin \left(\frac{\text{Adapter Angle} + \text{Work Angle}}{\cos (\text{Adapter Angle})} \right)}$$

Ask Customer Service for design templates on our website or CD.
Picture not representative of all angles.

All dimensions are for reference only.
No tolerance is stated or implied.

Aerial Cam – 300 mm

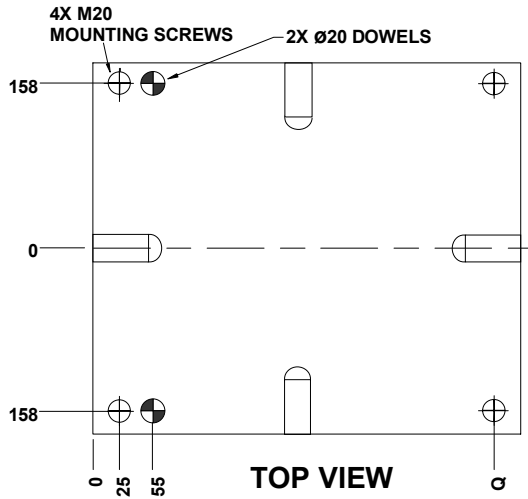

WORK ANGLE	Q	T	U
0°	320	170	210
5°	335	170	210
10°	345	170	210
15°	355	170	210
20°	370	170	210
25°	375	160	200
30°	375	145	185
35°	375	145	185
40°	375	135	175
45°	375	130	170
50°	350	135	175
55°	350	135	175
60°	350	135	175

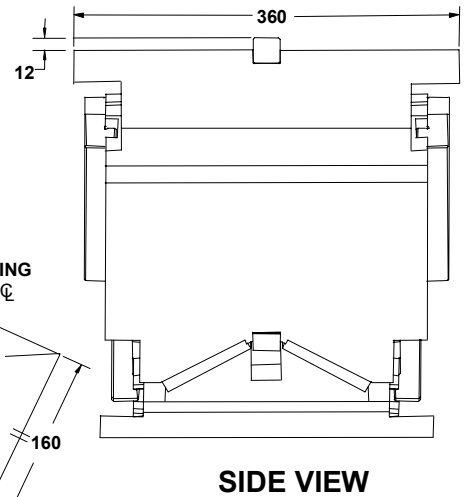
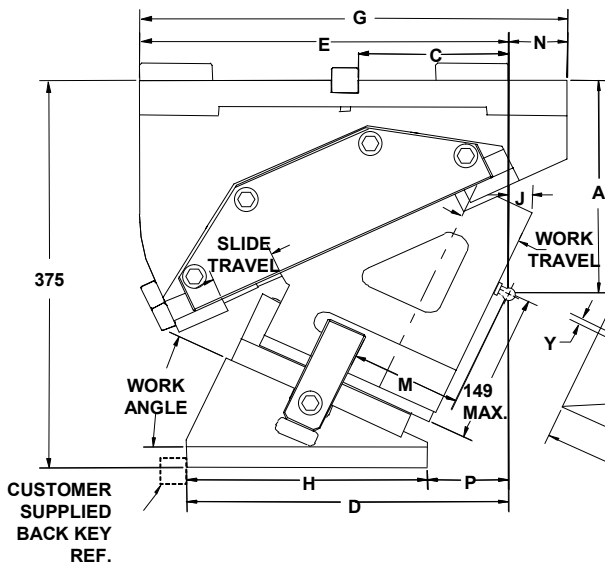
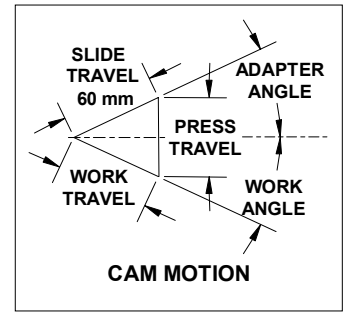

TOOLING MOUNTING FACE

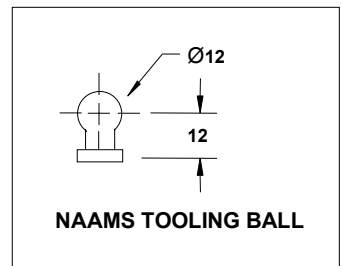
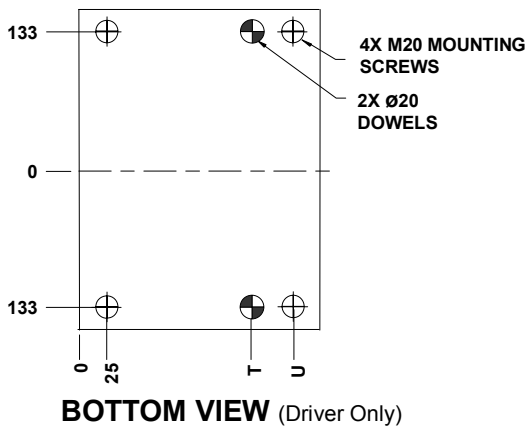

Tooling ball is not supplied with the cam and is a reference point only.

*Tooling ball located at "A" dimension per NAAMS.
"Y" dimension represents the tooling ball from the slide centerline.
Dowel holes undersized 0.2/0.3mm.
All dimensions are for reference only.
No tolerance is stated or implied.*

Ask Customer Service for design templates on our website or CD.
Picture not representative of all angles.

Aerial Cam – 300 mm

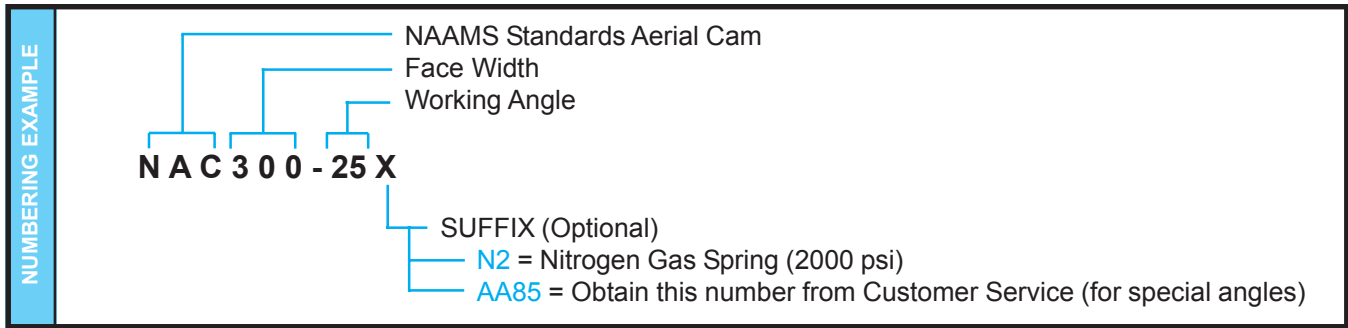

Part Number	NAAMS Number	Work Angle	Adapt Angle	Work Travel (mm)	A (mm)	C (mm)	D (mm)	E (mm)	G (mm)	H (mm)	J (mm)	M (mm)	N (mm)	P (mm)	Y (mm)
NAC300-00	C133000	0	50	38.6	180.0	193.0	242.0	345	345	235	-12.0	103.0	0.0	7.0	14.1
NAC300-05	C133005	5	45	42.6	185.0	182.5	255.7	350	360	235	-4.1	103.0	10.0	20.7	10.7
NAC300-10	C133010	10	40	46.7	190.0	172.0	269.8	350	370	235	3.1	103.0	20.0	34.8	6.0
NAC300-15	C133015	15	35	50.9	195.0	161.5	283.3	350	380	235	10.5	103.0	30.0	48.3	5.2
NAC300-20	C133020	20	30	55.3	200.0	151.0	296.8	345	395	235	17.2	103.0	50.0	61.8	3.1
NAC300-25	C133025	25	25	60.0	205.0	140.5	300.6	345	400	225	22.8	103.0	55.0	75.6	-0.3
NAC300-30	C133030	30	20	65.1	215.0	130.0	297.0	335	400	210	29.9	103.0	65.0	87.0	0.5
NAC300-35	C133035	35	15	70.8	225.0	121.0	308.1	320	400	210	36.2	103.0	80.0	98.1	0.2
NAC300-40	C133040	40	10	77.1	235.0	112.0	309.1	315	400	200	41.3	103.0	85.0	109.1	-1.4
NAC300-45	C133045	45	5	84.5	245.0	103.0	315.3	310	400	195	45.0	103.0	90.0	120.3	-4.4
NAC300-50	C133050	50	0	93.3	265.0	94.0	320.1	289.8	375	200	58.5	103.0	85.2	120.1	6.5
NAC300-55	C133055	55	0	104.6	285.0	86.5	325.2	277.5	375	200	68.2	108.0	97.5	125.2	11.6
NAC300-60	C133060	60	0	120.0	300.0	79.0	326.9	263	375	200	76.3	108.0	112.0	126.9	15.0

Max. Work Force	Slide Travel	Mechanical Spring Return Force	Nitrogen Spring Return Force ¹	# Optional Nitrogen Cylinder Pockets ²	Return Force per Nitrogen Spring Set	Maximum Tooling Weight		Maximum Tooling Envelope ³		Approx. Cam Unit Weight
(KN/Tons)	(mm)	Final (Kg/Lbs) [Four Springs]	Final (Kg/Lbs) [Two Springs]		Final (Kg/Lbs)	Weight (Kg/Lbs) Mechanical Spring	Weight (Kg/Lbs) Nitrogen Spring	Protrusion (mm)	Tooling Overhang per side of Slide (mm)	(Kg/Lbs)
444/50	60	912.4/2016	640/1410	2	320/705	65/143	130/287	200	50	227/500

¹Nitrogen cylinders do not have a pre-load. Listed nitrogen ratings are at the end of their stroke.

²Four spring pockets built into the cam, two nitrogen springs supplied with nitrogen spring configuration. Spring return calculated based on the standard spring quantity. Customer can add an additional one or two springs for more return force.

³Exceeding the maximum tooling envelope will reduce cam performance and shorten the life of the cam.

- ◆ Accelerator included (0° – 45°)

$$\text{PRESS TRAVEL} = \text{Work Travel} \times \frac{\sin \left(\frac{\text{Adapter Angle} + \text{Work Angle}}{\cos (\text{Adapter Angle})} \right)}$$

Ask Customer Service for design templates on our website or CD.
Picture not representative of all angles.

All dimensions are for reference only.
No tolerance is stated or implied.

Die Mount Cam – 50 mm

WORK ANGLE	Q
0°	150
5°	160
10°	165
15°	170
20°	170

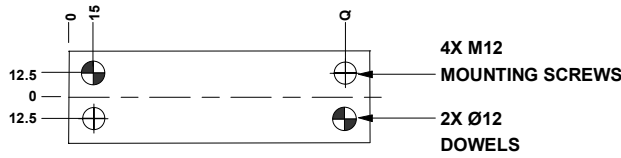

TOP VIEW (Driver only)

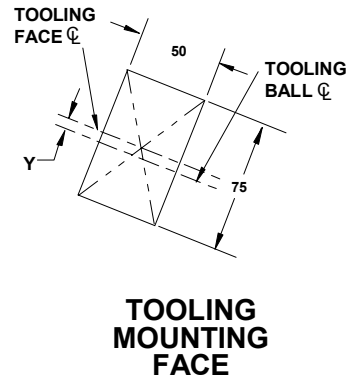
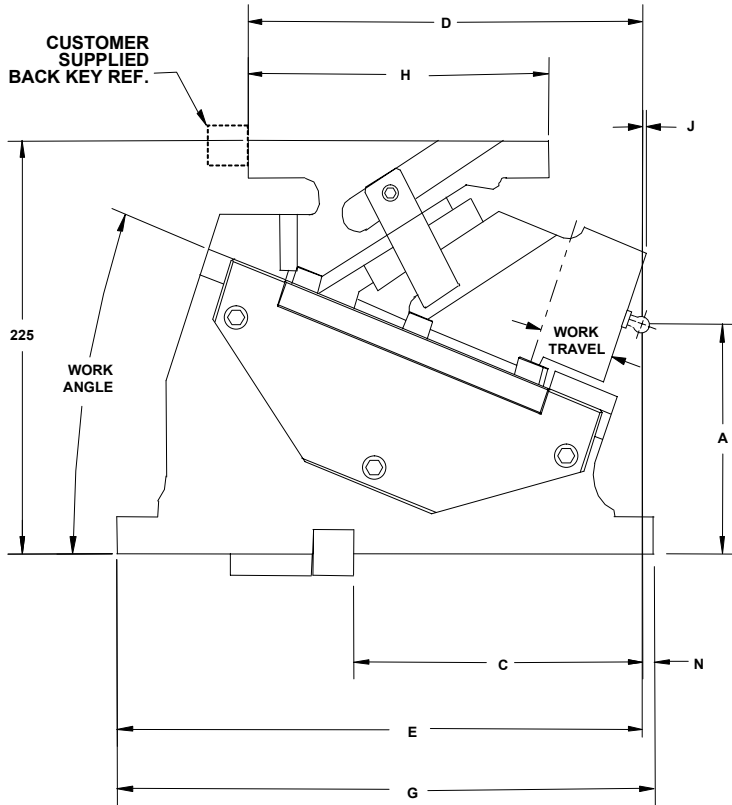

TOOLING MOUNTING FACE

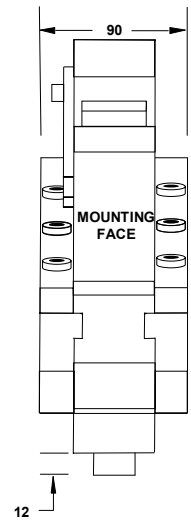

SIDE VIEW

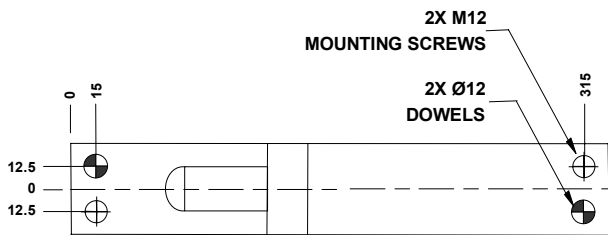

BOTTOM VIEW (Body only)

Tooling ball is not supplied with the cam and is a reference point only.

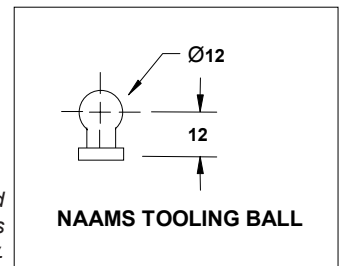

*Tooling ball located at "A" dimension per NAAMS.
 "Y" dimension represents the tooling ball from the slide centerline.
 Dowel holes undersized 0.2/0.3mm.
 All dimensions are for reference only.
 No tolerance is stated or implied.*

Ask Customer Service for design templates on our website or CD.
 Picture not representative of all angles.

Die Mount Cam – 50 mm

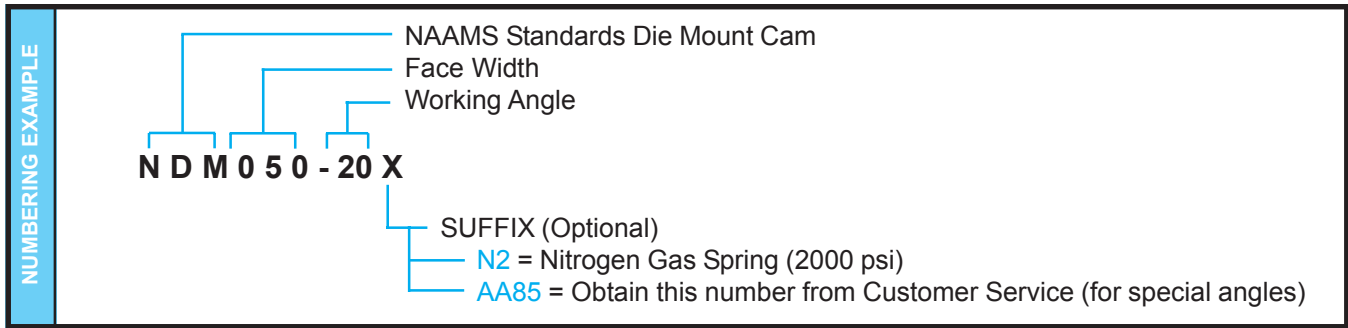

Part Number	NAAMS Number	Work Angle	Work Travel (mm)	A (mm)	C (mm)	D (mm)	E (mm)	G (mm)	H (mm)	J (mm)	N (mm)	Y (mm)
NDM050-00	C230500	0	45	160	170.0	242.0	292.0	330	165	-12	38.0	0.0
NDM050-05	C230505	5	45	150	180.0	247.5	300.0	330	175	-8.7	30.0	0.0
NDM050-10	C230510	10	45	140	190.0	248.0	308.0	330	180	-5.3	22.0	0.0
NDM050-15	C230515	15	45	135	200.0	250.8	325.3	330	185	-1.9	4.7	0.0
NDM050-20	C230520	20	45	130	210.0	247.8	325.3	330	185	-1.6	4.7	0.0

Max. Work Force	Slide Travel	Mechanical Spring Return Force	Nitrogen Spring Return Force ¹	Maximum Tooling Weight		Maximum Tooling Envelope ²		Approx. Cam Unit Weight
(KN/Tons)	(mm)	Final (Kg/Lbs) [One Spring]	Final (Kg/Lbs) [One Spring]	Weight (Kg/Lbs) Mechanical Spring	Weight (Kg/Lbs) Nitrogen Spring	Protrusion (mm)	Tooling Overhang per side of Slide (mm)	(Kg/Lbs)
134/15	45	58/128	94/208	8/18	16/35	125	25	28/60

¹Optional nitrogen cylinders do not have a pre-load. Listed nitrogen ratings are at the end of their stroke.

²Exceeding the maximum tooling envelope will reduce cam performance and shorten the life of the cam.

Die Mount Cam – 75 mm

WORK ANGLE	Q
0°	167
5°	172
10°	182
15°	182
20°	182

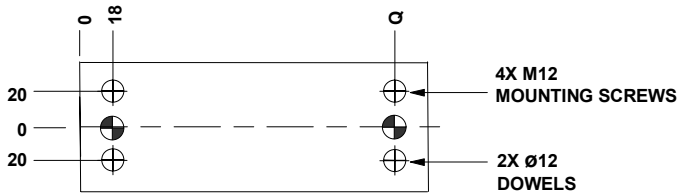

TOP VIEW (Driver Only)

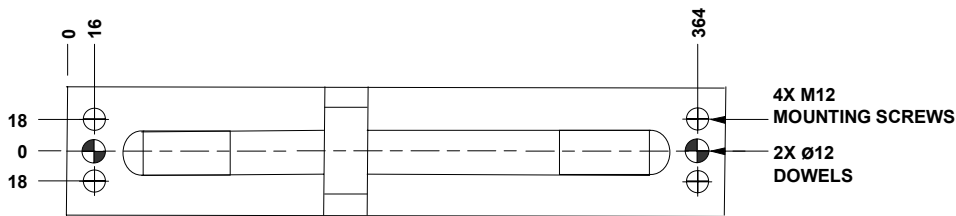
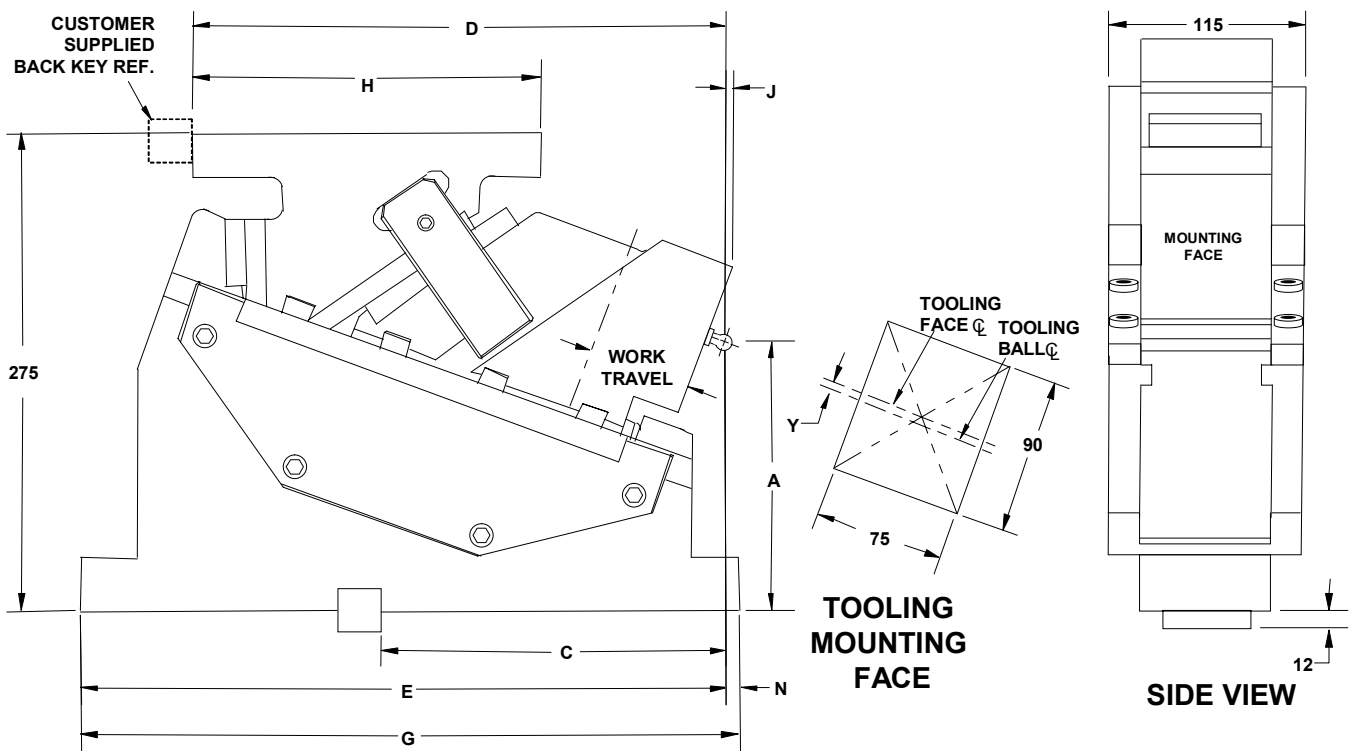

BOTTOM VIEW (Body Only)

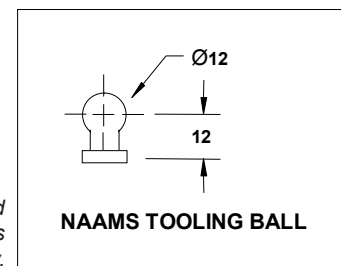

Tooling ball is not supplied with the cam and is a reference point only.

*Tooling ball located at "A" dimension per NAAMS.
"Y" dimension represents the tooling ball from the slide centerline.
Dowel holes undersized 0.2/0.3mm.
All dimensions are for reference only.
No tolerance is stated or implied.*

Ask Customer Service for design templates on our website or CD.
Picture not representative of all angles.

Die Mount Cam – 75 mm

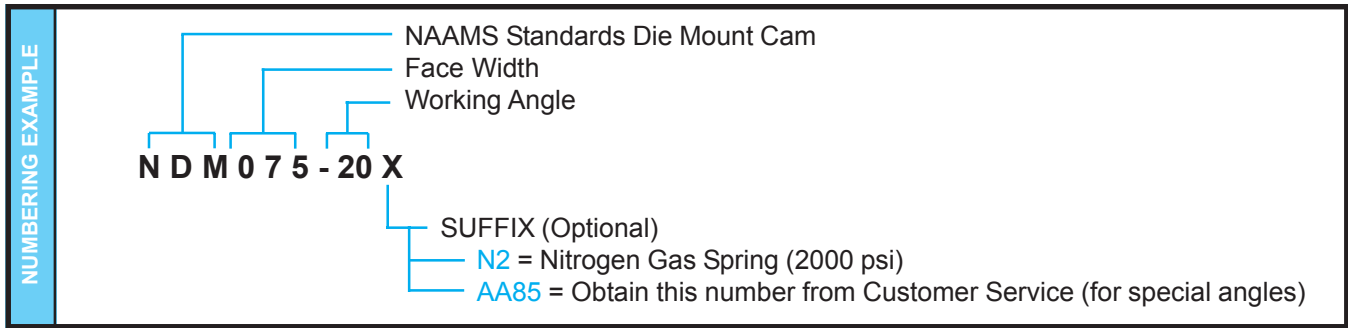

Part Number	NAAMS Number	Work Angle	Work Travel (mm)	A (mm)	C (mm)	D (mm)	E (mm)	G (mm)	H (mm)	J (mm)	N (mm)	Y (mm)
NDM075-00	C230700	0	60	200	170	296	340	380	185	-12	40	-6
NDM075-05	C230705	5	60	190	180	300.3	352	380	190	-8.6	28	-6.3
NDM075-10	C230710	10	60	175	190	304.9	362.9	380	200	-4.5	17.1	-2.6
NDM075-15	C230715	15	60	165	200	308.3	364.1	380	200	-1.2	15.9	-5
NDM075-20	C230720	20	60	155	210	308.5	373.6	380	200	3.1	6.4	-3.1

Max. Work Force (KN/Tons)	Slide Travel (mm)	Mechanical Spring Return Force	Nitrogen Spring Return Force ¹	Maximum Tooling Weight		Maximum Tooling Envelope ²		Approx. Cam Unit Weight (Kg/Lbs)
		Final (Kg/Lbs) [One Spring]	Final (Kg/Lbs) [One Spring]	Weight (Kg/Lbs) Mechanical Spring	Weight (Kg/Lbs) Nitrogen Spring	Protrusion (mm)	Tooling Overhang per side of Slide (mm)	
134/15	60	229/505	340/748	12/26	24/535	140	25	53/115

¹Optional nitrogen cylinders do not have a pre-load. Listed nitrogen ratings are at the end of their stroke.

²Exceeding the maximum tooling envelope will reduce cam performance and shorten the life of the cam.

Die Mount Cam – 150 mm

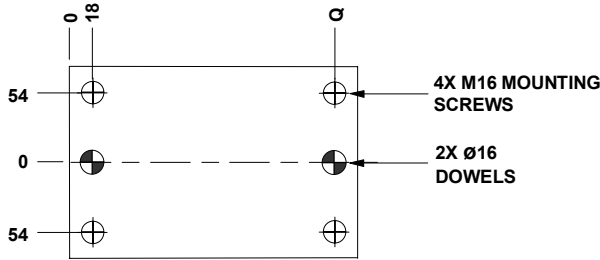

TOP VIEW (Driver Only)

WORK ANGLE	Q
0°	177
5°	177
10°	182
15°	192
20°	207

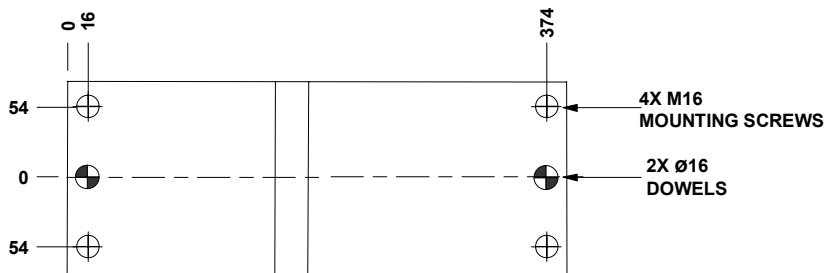
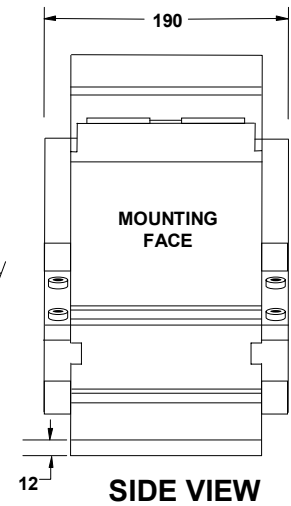
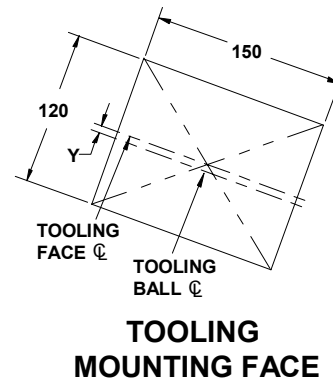
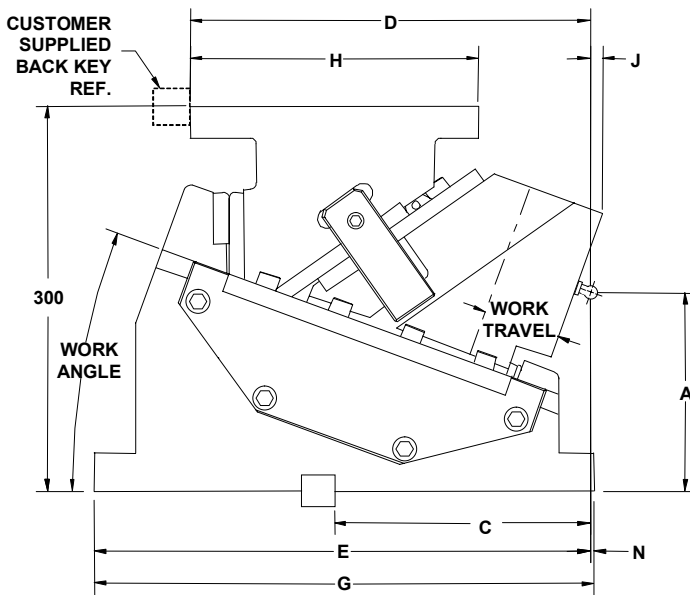

BOTTOM VIEW (Body Only)

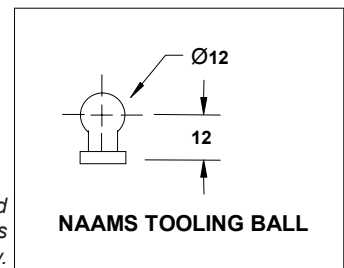

Tooling ball is not supplied with the cam and is a reference point only.

*Tooling ball located at "A" dimension per NAAMS.
 "Y" dimension represents the tooling ball from the slide centerline.
 Dowel holes undersized 0.2/0.3mm.
 All dimensions are for reference only.
 No tolerance is stated or implied.*

Ask Customer Service for design templates on our website or CD.
 Picture not representative of all angles.

Die Mount Cam – 150 mm

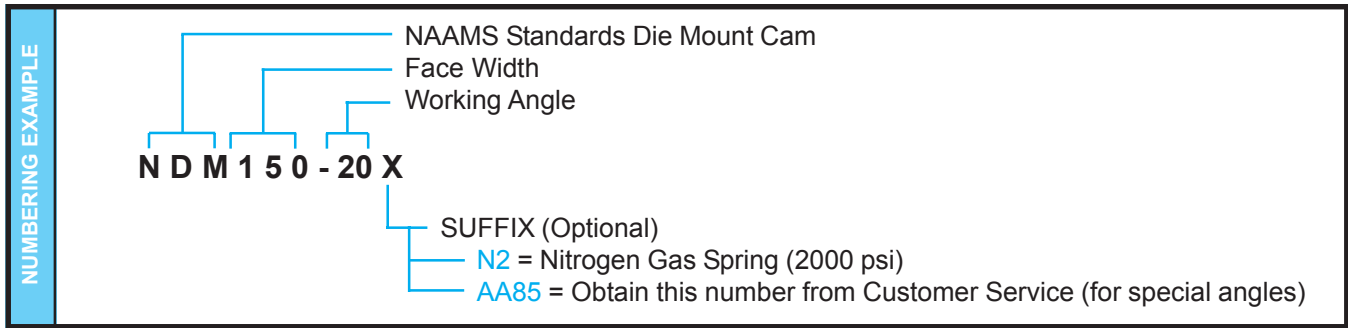

Part Number	NAAMS Number	Work Angle	Work Travel (mm)	A (mm)	C (mm)	D (mm)	E (mm)	G (mm)	H (mm)	J (mm)	N (mm)	Y (mm)
NDM150-00	C231500	0	60	200	170.0	296.0	350.0	390	195	-12	40.0	-1.0
NDM150-05	C231505	5	60	190	180.0	301.2	362.9	390	195	-6.8	27.1	-1.4
NDM150-10	C231510	10	60	175	190.0	306.7	374.7	390	200	-1	15.3	2.2
NDM150-15	C231515	15	60	165	200.0	311.0	376.8	390	210	3.9	13.2	-0.3
NDM150-20	C231520	20	60	155	210.0	312.2	387.2	390	225	9.7	2.8	1.3

Max. Work Force (KN/Tons)	Slide Travel (mm)	Mechanical Spring Return Force	Nitrogen Spring Return Force ¹	Maximum Tooling Weight		Maximum Tooling Envelope ²		Approx. Cam Unit Weight (Kg/Lbs)
		Final (Kg/Lbs) [Two Springs]	Final (Kg/Lbs) [Two Springs]	Weight (Kg/Lbs) Mechanical Spring	Weight (Kg/Lbs) Nitrogen Spring	Protrusion (mm)	Tooling Overhang per side of Slide (mm)	
223/25	60	458/1010	680/1496	20/44	40/88	150	45	100/220

¹Optional nitrogen cylinders do not have a pre-load. Listed nitrogen ratings are at the end of their stroke.

²Exceeding the maximum tooling envelope will reduce cam performance and shorten the life of the cam.

- ◆ Accelerator included (0° – 20°)

Die Mount Cam – 200 mm

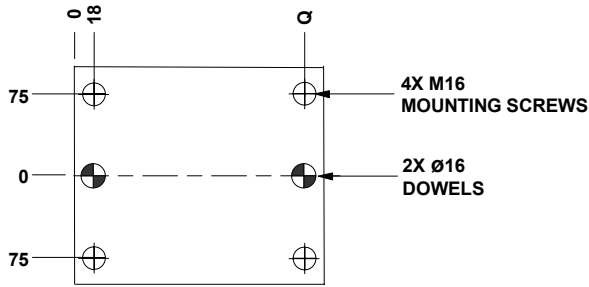

TOP VIEW (Driver Only)

WORK ANGLE	Q
0°	177
5°	177
10°	182
15°	192
20°	207

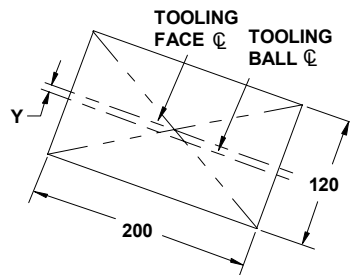
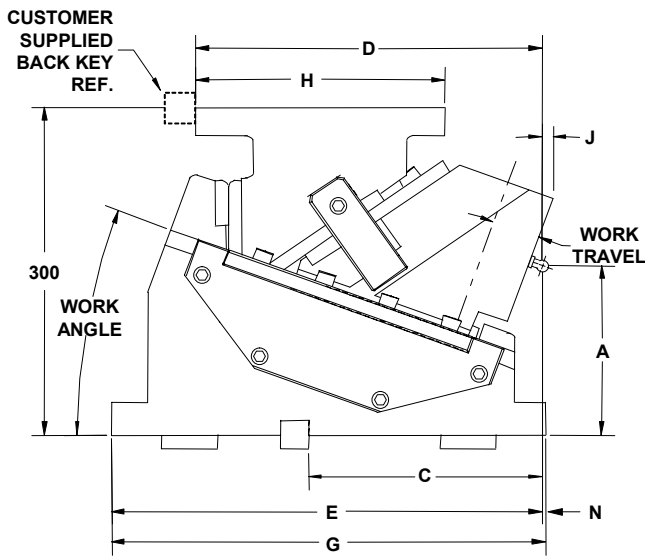

TOOLING MOUNTING FACE

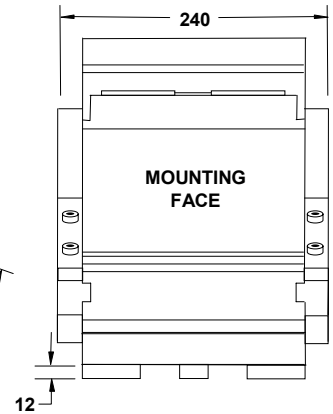

SIDE VIEW

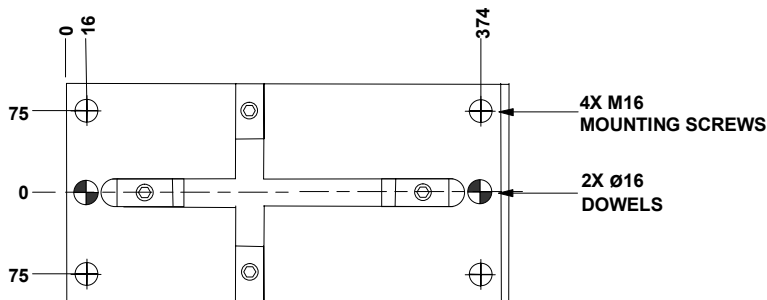

BOTTOM VIEW (Body Only)

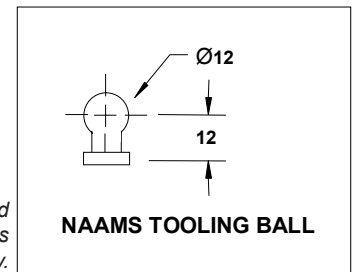

Tooling ball is not supplied with the cam and is a reference point only.

*Tooling ball located at "A" dimension per NAAMS.
 "Y" dimension represents the tooling ball from the slide centerline.
 Dowel holes undersized 0.2/0.3mm.
 All dimensions are for reference only.
 No tolerance is stated or implied.*

Ask Customer Service for design templates on our website or CD.
 Picture not representative of all angles.

Die Mount Cam – 200 mm

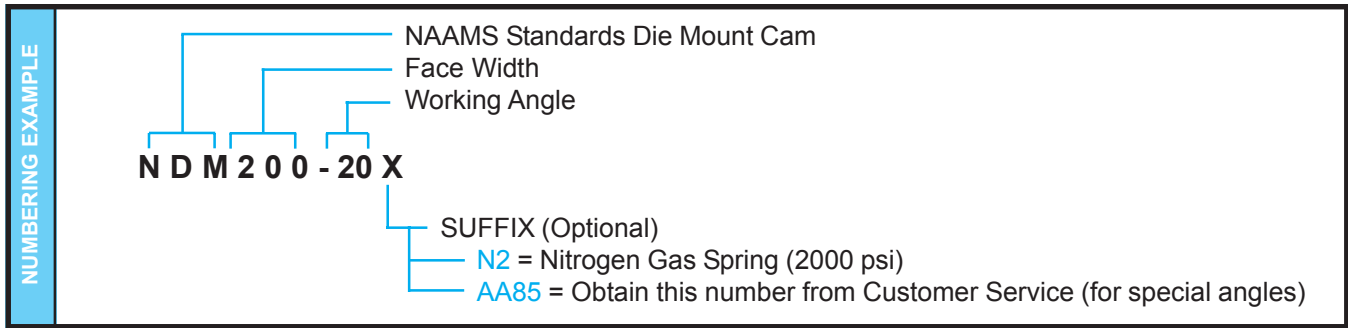

Part Number	NAAMS Number	Work Angle	Work Travel (mm)	A (mm)	C (mm)	D (mm)	E (mm)	G (mm)	H (mm)	J (mm)	N (mm)	Y (mm)
NDM200-00	C232000	0	60	200	170.0	296.0	350.0	390	195	-12	40.0	-1.0
NDM200-05	C232005	5	60	190	180.0	301.2	362.9	390	195	-6.8	27.1	-1.4
NDM200-10	C232010	10	60	175	190.0	306.7	374.7	390	200	-1	15.3	2.2
NDM200-15	C232015	15	60	165	200.1	311.0	376.8	390	210	3.9	13.2	-0.3
NDM200-20	C232020	20	60	155	210.0	312.2	387.2	390	225	9.7	2.8	1.3

Max. Work Force	Slide Travel	Mechanical Spring Return Force	Nitrogen Spring Return Force ¹	# Optional Nitrogen Cylinder Pockets ²	Return Force per Nitrogen Spring	Maximum Tooling Weight		Maximum Tooling Envelope ³		Approx. Cam Unit Weight
(KN/Tons)	(mm)	Final (Kg/Lbs) [Three Springs]	Final (Kg/Lbs) [Two Springs]		Final (Kg/Lbs)	Weight (Kg/Lbs) Mechanical Spring	Weight (Kg/Lbs) Nitrogen Spring	Protrusion (mm)	Tooling Overhang per side of Slide (mm)	(Kg/Lbs)
312/35	60	687/1515	680/1496	1	340/748	32/71	64/141	175	45	141/310

¹Nitrogen cylinders do not have a pre-load. Listed nitrogen ratings are at the end of their stroke.

²Three spring pockets built into the cam, two nitrogen springs supplied with nitrogen spring configuration. Spring return calculated based on the standard spring quantity. Customer can add an additional spring for more return force.

³Exceeding the maximum tooling envelope will reduce cam performance and shorten the life of the cam.

- ◆ Accelerator included (0° – 20°)

Die Mount Cam – 250 mm

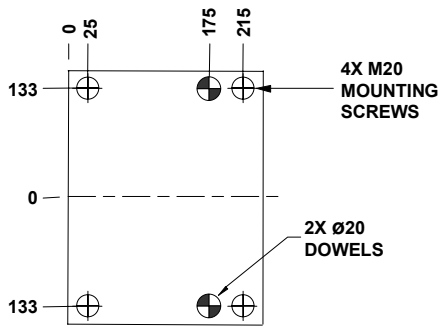

TOP VIEW (Driver Only)

WORK ANGLE	U
0°	350
5°	375
10°	375
15°	375
20°	375

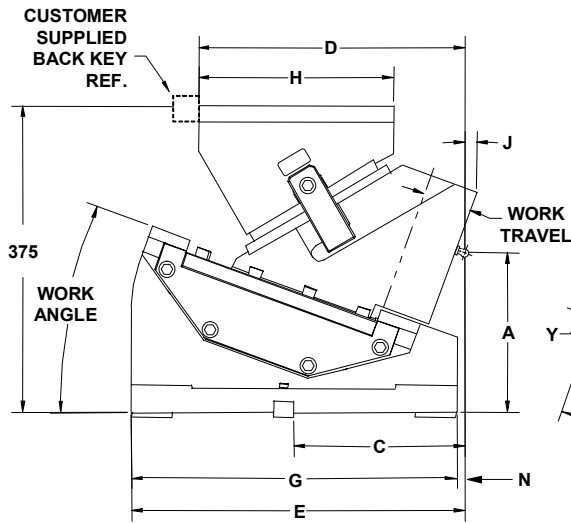

TOOLING MOUNTING FACE

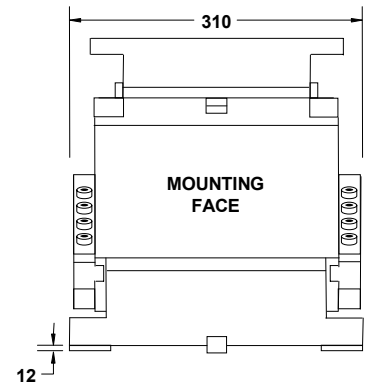

SIDE VIEW

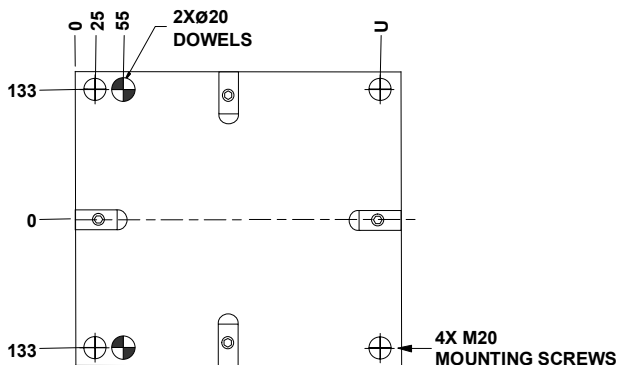

BOTTOM VIEW (Body Only)

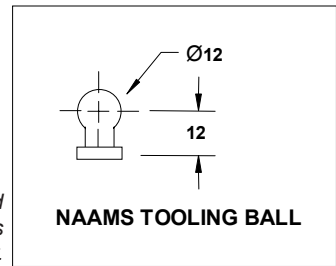

Tooling ball is not supplied with the cam and is a reference point only.

NAAMS TOOLING BALL

Ask Customer Service for design templates on our website or CD.
Picture not representative of all angles.

*Tooling ball located at "A" dimension per NAAMS.
"Y" dimension represents the tooling ball from the slide centerline.
Dowel holes undersized 0.2/0.3mm.
All dimensions are for reference only.
No tolerance is stated or implied.*

Die Mount Cam – 250 mm

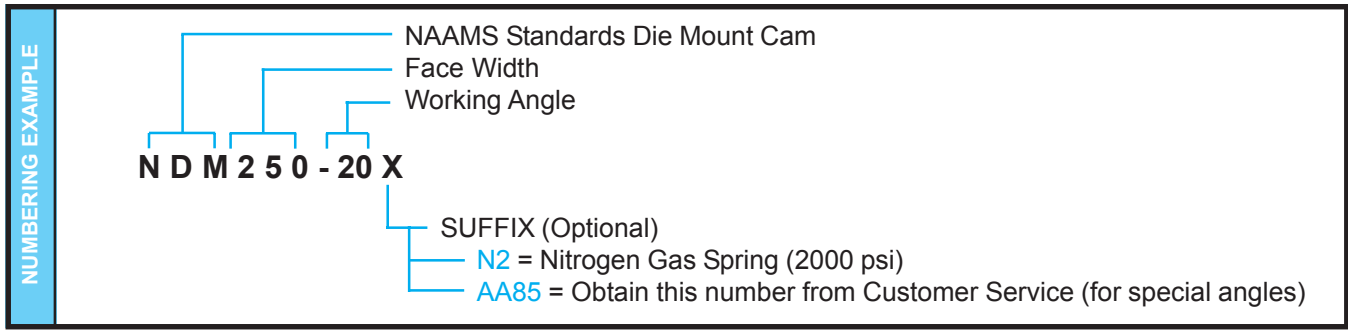

Part Number	NAAMS Number	Work Angle	Work Travel (mm)	A (mm)	C (mm)	D (mm)	E (mm)	G (mm)	H (mm)	J (mm)	N (mm)	Y (mm)
NDM250-00	C232500	0	60	260	170.0	359.2	372.0	375	240	-12	3.0	-3.4
NDM250-05	C232505	5	60	235	180.0	351.6	383.3	400	240	-4.4	16.7	2.1
NDM250-10	C232510	10	60	225	190.0	344.6	390.6	400	240	1.8	9.4	-6.6
NDM250-15	C232515	15	60	210	200.0	336.5	396.0	400	240	7.9	4.0	-9.5
NDM250-20	C232520	20	60	195	210.0	327.6	410.3	400	240	13.9	-10.3	-11.5

Max. Work Force (KN/Tons)	Slide Travel (mm)	Mechanical Spring Return Force	Nitrogen Spring Return Force ¹	# Optional Nitrogen Cylinder Pockets ²	Return Force per Nitrogen Spring	Maximum Tooling Weight		Maximum Tooling Envelope ³		Approx. Cam Unit Weight (Kg/Lbs)
		Final (Kg/Lbs) [Three Springs]	Final (Kg/Lbs) [Two Springs]			Weight (Kg/Lbs) Mechanical Spring	Weight (Kg/Lbs) Nitrogen Spring	Protrusion (mm)	Tooling Overhang per side of Slide (mm)	
356/40	60	687/1515	640/1410	1	320/705	65/143	130/287	200	40	227/500

¹Nitrogen cylinders do not have a pre-load. Listed nitrogen ratings are at the end of their stroke.

²Three spring pockets built into the cam, two nitrogen springs supplied with nitrogen spring configuration. Spring return calculated based on the standard spring quantity. Customer can add an additional spring for more return force.

³Exceeding the maximum tooling envelope will reduce cam performance and shorten the life of the cam.

- ◆ Accelerator included (0° – 20°)

Die Mount Cam – 300 mm

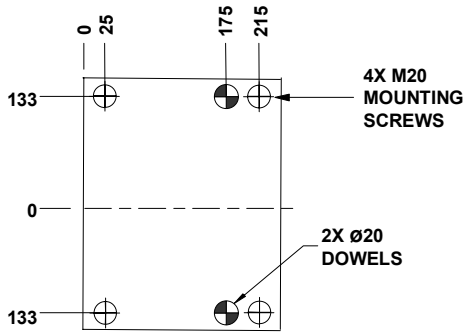

TOP VIEW (Driver Only)

WORK ANGLE	U
0°	350
5°	375
10°	375
15°	375
20°	375

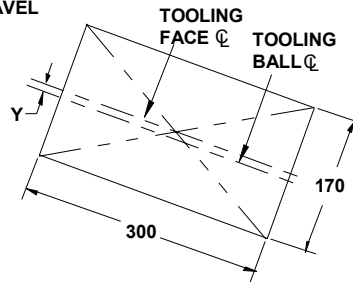
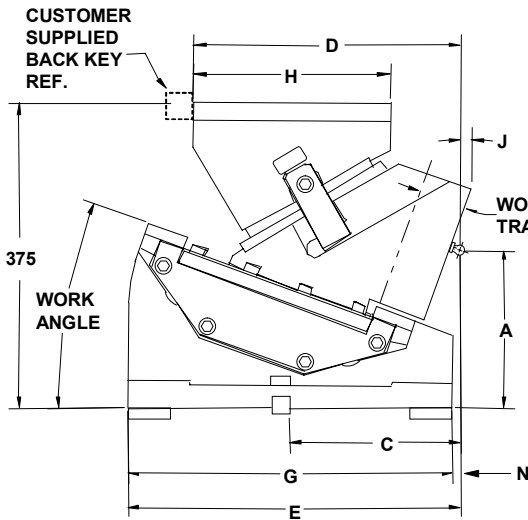

TOOLING MOUNTING FACE

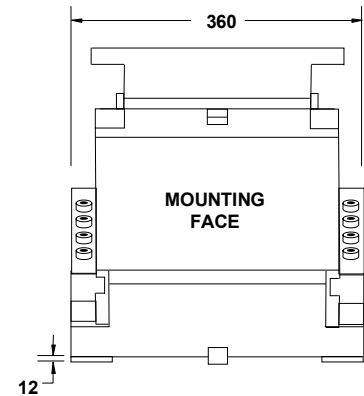

SIDE VIEW

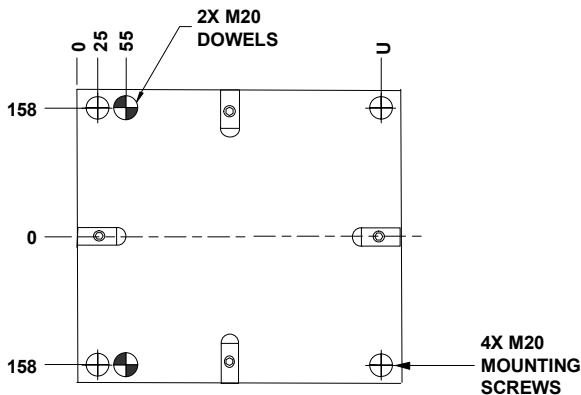

BOTTOM VIEW (Body Only)

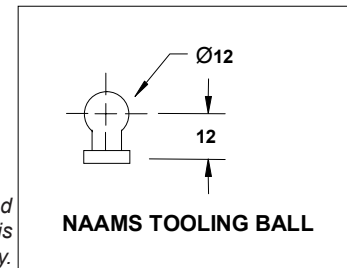

Tooling ball is not supplied with the cam and is a reference point only.

*Tooling ball located at "A" dimension per NAAMS.
 "Y" dimension represents the tooling ball from the slide centerline.
 Dowel holes undersized 0.2/0.3mm.
 All dimensions are for reference only.
 No tolerance is stated or implied.*

Ask Customer Service for design templates on our website or CD.
 Picture not representative of all angles.

Die Mount Cam – 300 mm

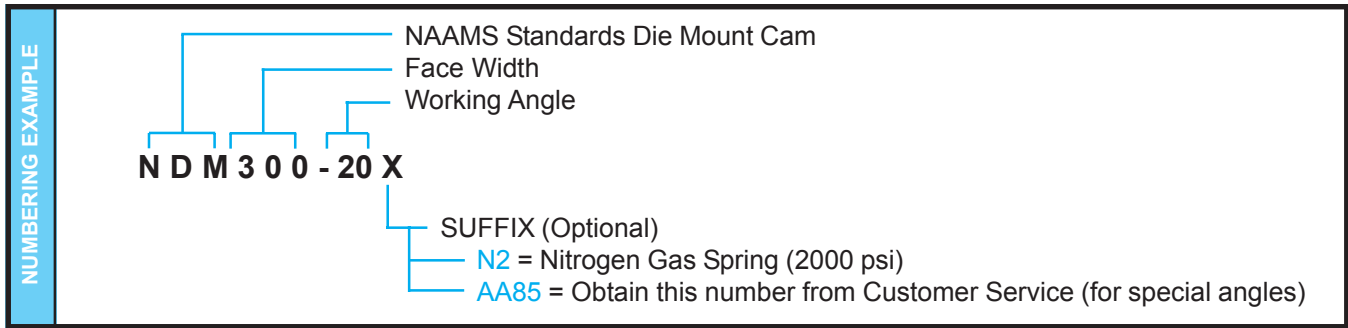

Part Number	NAAMS Number	Work Angle	Work Travel (mm)	A (mm)	C (mm)	D (mm)	E (mm)	G (mm)	H (mm)	J (mm)	N (mm)	Y (mm)
NDM300-00	C233000	0	60	260	170.0	359.2	372.0	375	240	-12	3.0	-3.4
NDM300-05	C233005	5	60	235	180.0	351.6	383.3	400	240	-4.4	16.7	2.1
NDM300-10	C233010	10	60	225	190.0	344.6	390.6	400	240	1.8	9.4	-6.6
NDM300-15	C233015	15	60	210	200.0	336.5	396.0	400	240	7.9	4.0	-9.5
NDM300-20	C233020	20	60	195	210.0	327.6	410.3	400	240	13.9	-10.3	-11.5

Max. Work Force	Slide Travel	Mechanical Spring Return Force	Nitrogen Spring Return Force ¹	# Optional Nitrogen Cylinder Pockets ²	Return Force per Nitrogen Spring	Maximum Tooling Weight		Maximum Tooling Envelope ³		Approx. Cam Unit Weight
(KN/Tons)	(mm)	Final (Kg/Lbs) [Four Springs]	Final (Kg/Lbs) [Two Springs]		Final (Kg/Lbs) Mechanical Spring	Weight (Kg/Lbs) Nitrogen Spring	Weight (Kg/Lbs)	Protrusion (mm)	Tooling Overhang per side of Slide (mm)	(Kg/Lbs)
444/50	60	916/2020	640/1410	2	320/705	65/143	130/287	200	50	254/560

¹Nitrogen cylinders do not have a pre-load. Listed nitrogen ratings are at the end of their stroke.

²Four spring pockets built into the cam, two nitrogen springs supplied with nitrogen spring configuration. Spring return calculated based on the standard spring quantity. Customer can add an additional one or two springs for more return force.

³Exceeding the maximum tooling envelope will reduce cam performance and shorten the life of the cam.

- ◆ Accelerator included (0° – 20°)

Notes

Long Reaching (Extra Travel) Die Mount Cams

When to use a LRD Cam

The Long Reaching (Extra Travel) Die Mount Cam line is designed to provide maximum clearance for material movement while optimizing the preferred kinematics associated with standard Die Mount Cams. The Long Reaching (Extra Travel) Die Mount Cam provides a sound alternative to the use of low angle aerial cams in transfer press operations and is part of our next generation of automotive and large die cams.

Designers will find the height and length of the 110mm travel Long Reaching (Extra Travel) Cam to be a perfect package providing 30% more slide travel than competitive cams. Take a look at the performance features and you will find it's easy to see why the Long Reaching Cam line will make everyone's job easier.

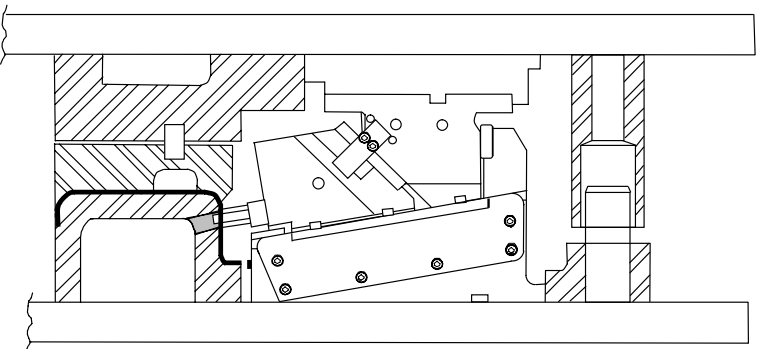
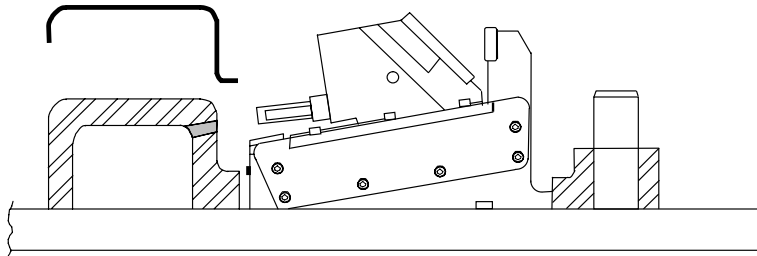
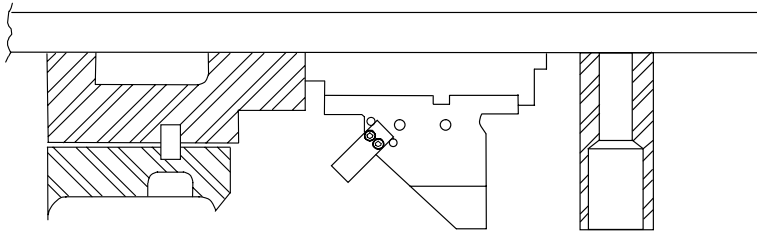

- ◆ 110mm slide travel allows unencumbered travel over part flanges
- ◆ Quick slide removal with top access keeper plate
- ◆ Side wear strip on slide for extra lubrication and ease of maintenance
- ◆ Reduce noise and wear with the optional accelerator (150 & 200 wide cams)
- ◆ Long lasting Aluminum Bronze Wear Plates against hardened steel surfaces
- ◆ Maintenance-free, self-lubricating components
- ◆ Optional, longer slide adds 35mm to reach
- ◆ Urethane bumper to cushion return
- ◆ ISO nitrogen cylinder with no pre-load
- ◆ Double protection with positive returns
- ◆ Ease of setup with slide lockout capability
- ◆ Rear spring access for ease of maintenance

Long Reaching (Extra Travel) Die Mount Cam – 75 mm

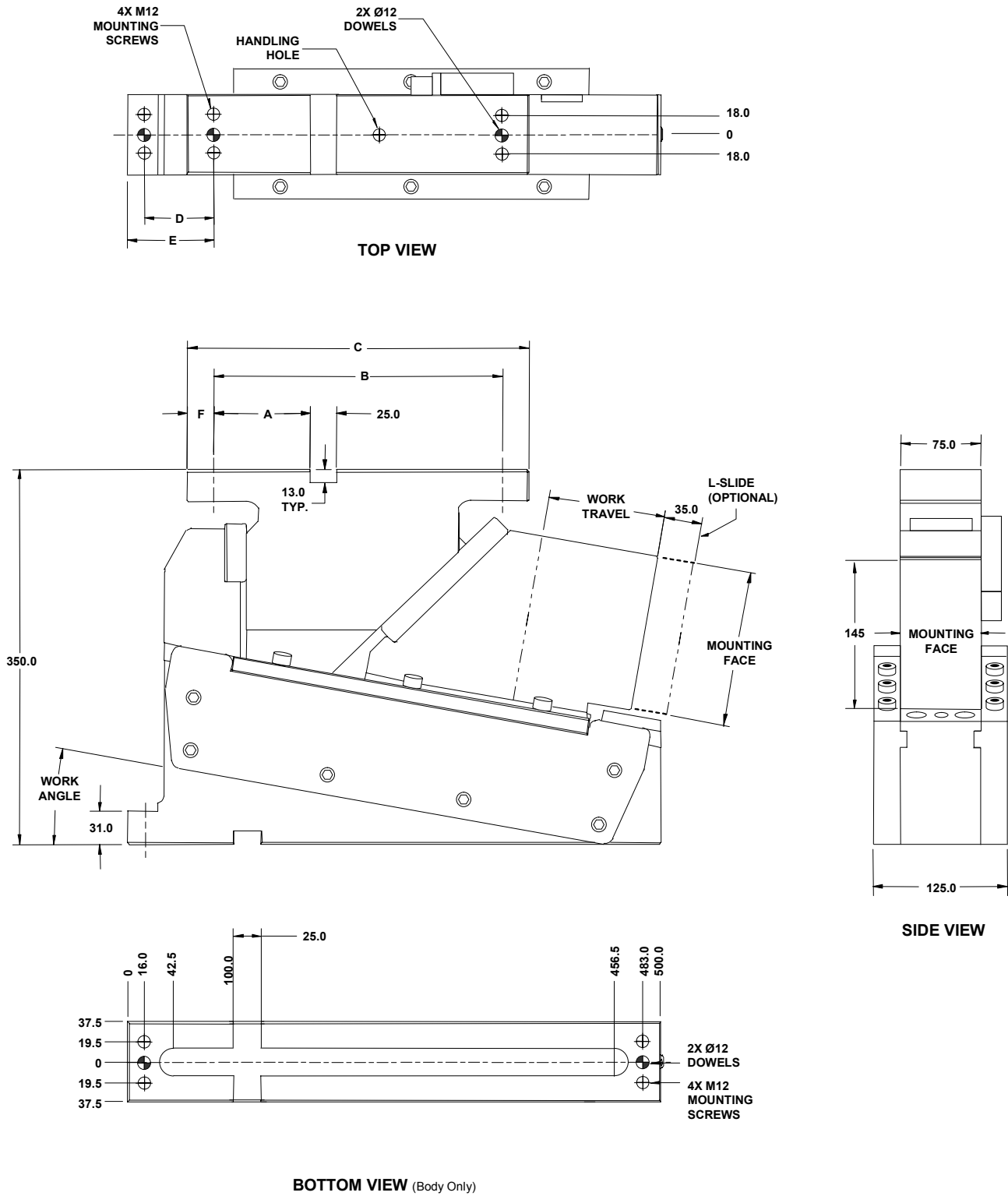

Ask Customer Service for design templates on our website or CD.
Picture not representative of all angles.

Dowel holes are press fit.
All dimensions are for reference only.
No tolerance is stated or implied.

Long Reaching (Extra Travel) Die Mount Cam – 75 mm

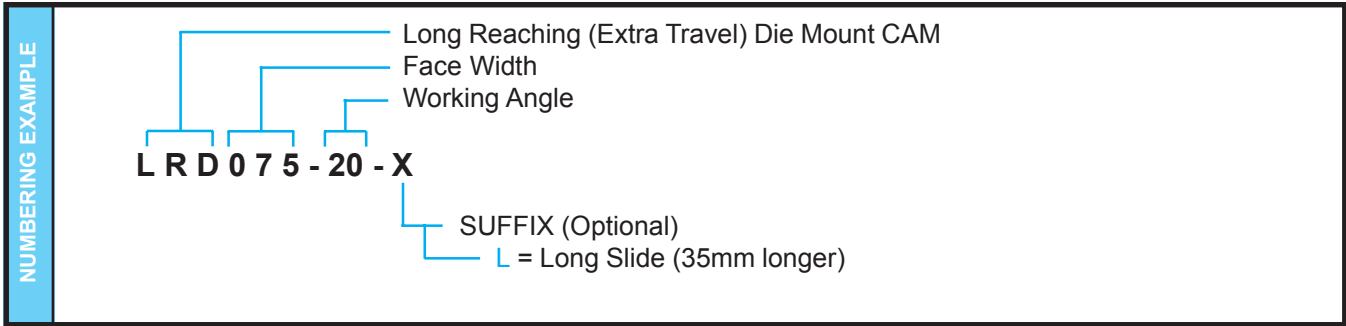

Part Number	Work Angle	Work Travel (mm)	A (mm)	B (mm)	C (mm)	D (mm)	E (mm)	F (mm)
LRD075-00	0	110	90	270	320	65	81	25
LRD075-05	5	110	90	270	320	65	81	25
LRD075-10	10	110	90	270	320	65	81	25
LRD075-15	15	110	30	210	260	125	141	30
LRD075-20	20	110	30	210	260	125	141	30

Max. Work Force (KN/Tons)	Slide Travel (mm)	Mechanical Spring Return Force	Nitrogen Spring Return Force ¹	Maximum Tooling Weight		Maximum Tooling Envelope ²		Approx. Cam Unit Weight (Kg/Lbs)
		Final (Kg/Lbs) [One Spring]	Final (Kg/Lbs) [One Spring]	Weight (Kg/Lbs) Mechanical Spring	Weight (Kg/Lbs) Nitrogen Spring	Protrusion (mm)	Tooling Overhang per side of Slide (mm)	
134/15	110	N/A	340/748	N/A	8/18	140	25	98/215

¹Optional nitrogen cylinders do not have a pre-load. Listed nitrogen ratings are at the end of their stroke.

²Exceeding the maximum tooling envelope will reduce cam performance and shorten the life of the cam.

Long Reaching (Extra Travel) Die Mount Cam – 150 mm

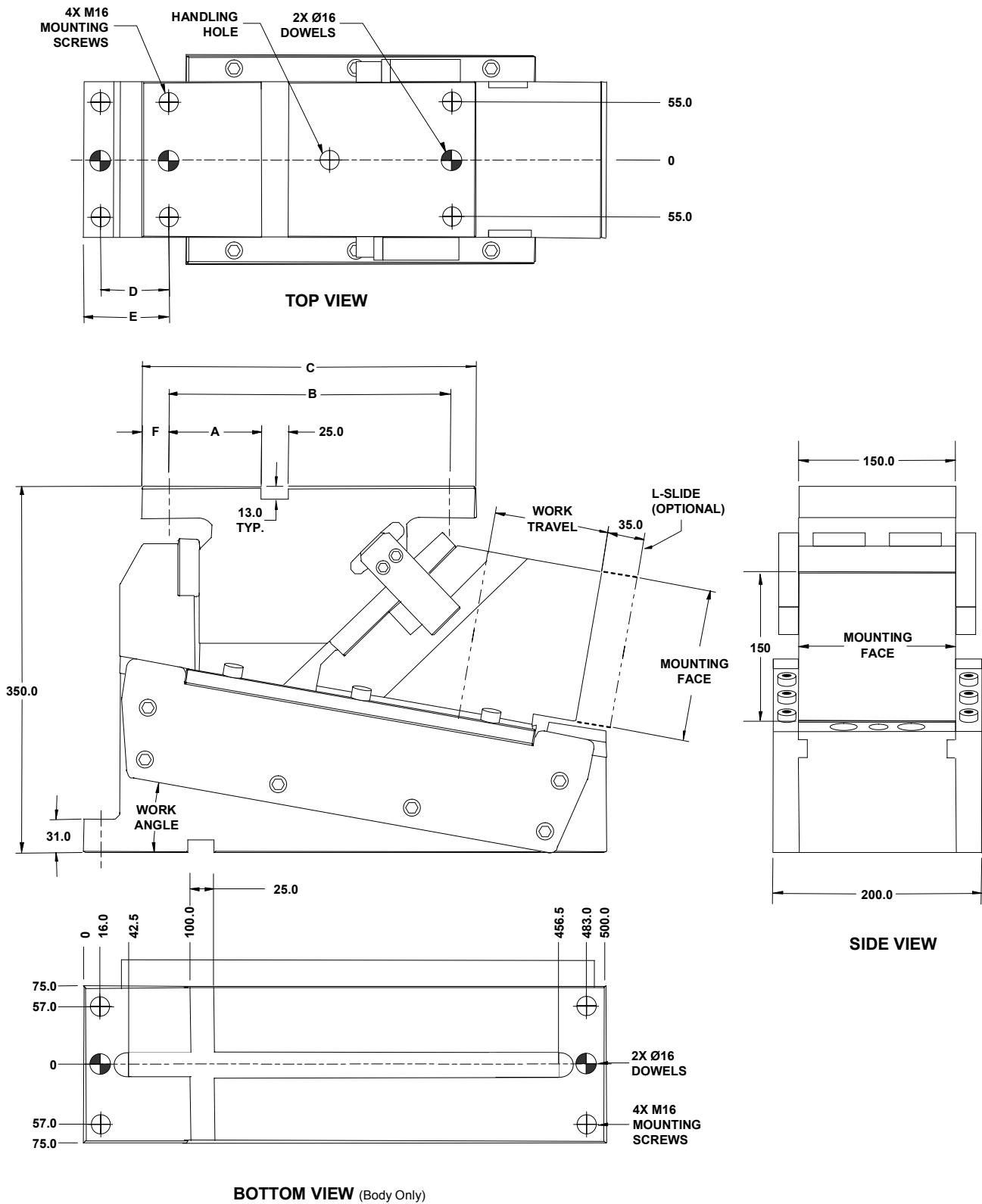

Ask Customer Service for design templates on our website or CD.
Picture not representative of all angles.

Dowel holes are press fit.
All dimensions are for reference only.
No tolerance is stated or implied.

Long Reaching (Extra Travel) Die Mount Cam – 150 mm

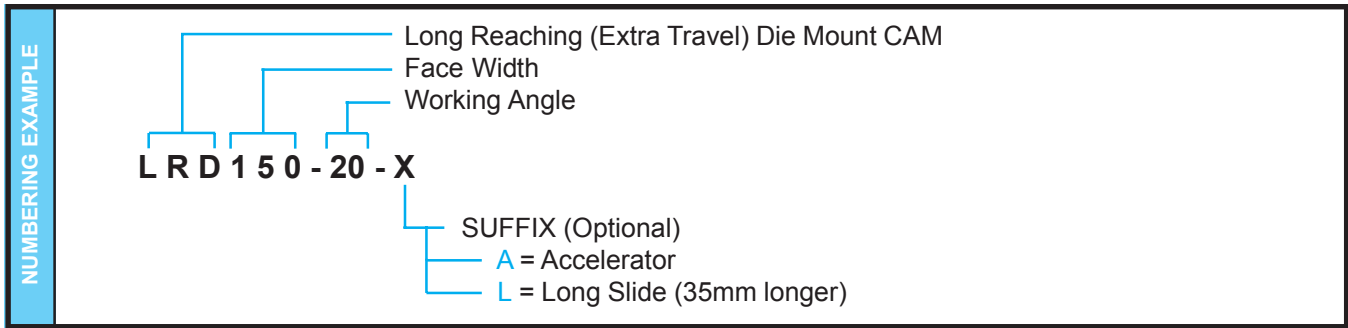

Part Number	Work Angle	Work Travel (mm)	A (mm)	B (mm)	C (mm)	D (mm)	E (mm)	F (mm)
LRD150-00	0	110	90	270	320	65	81	25
LRD150-05	5	110	90	270	320	65	81	25
LRD150-10	10	110	90	270	320	65	81	25
LRD150-15	15	110	30	210	260	125	141	30
LRD150-20	20	110	30	210	260	125	141	30

Max. Work Force (KN/Tons)	Slide Travel (mm)	Mechanical Spring Return Force	Nitrogen Spring Return Force ¹	Maximum Tooling Weight		Maximum Tooling Envelope ²		Approx. Cam Unit Weight (Kg/Lbs)
		Final (Kg/Lbs) [Two Springs]	Final (Kg/Lbs) [Two Springs]	Weight (Kg/Lbs) Mechanical Spring	Weight (Kg/Lbs) Nitrogen Spring	Protrusion (mm)	Tooling Overhang per side of Slide (mm)	
223/25	110	N/A	680/1498	N/A	12/26	150	45	179/395

¹Optional nitrogen cylinders do not have a pre-load. Listed nitrogen ratings are at the end of their stroke.

²Exceeding the maximum tooling envelope will reduce cam performance and shorten the life of the cam.

Long Reaching (Extra Travel) Die Mount Cam – 200 mm

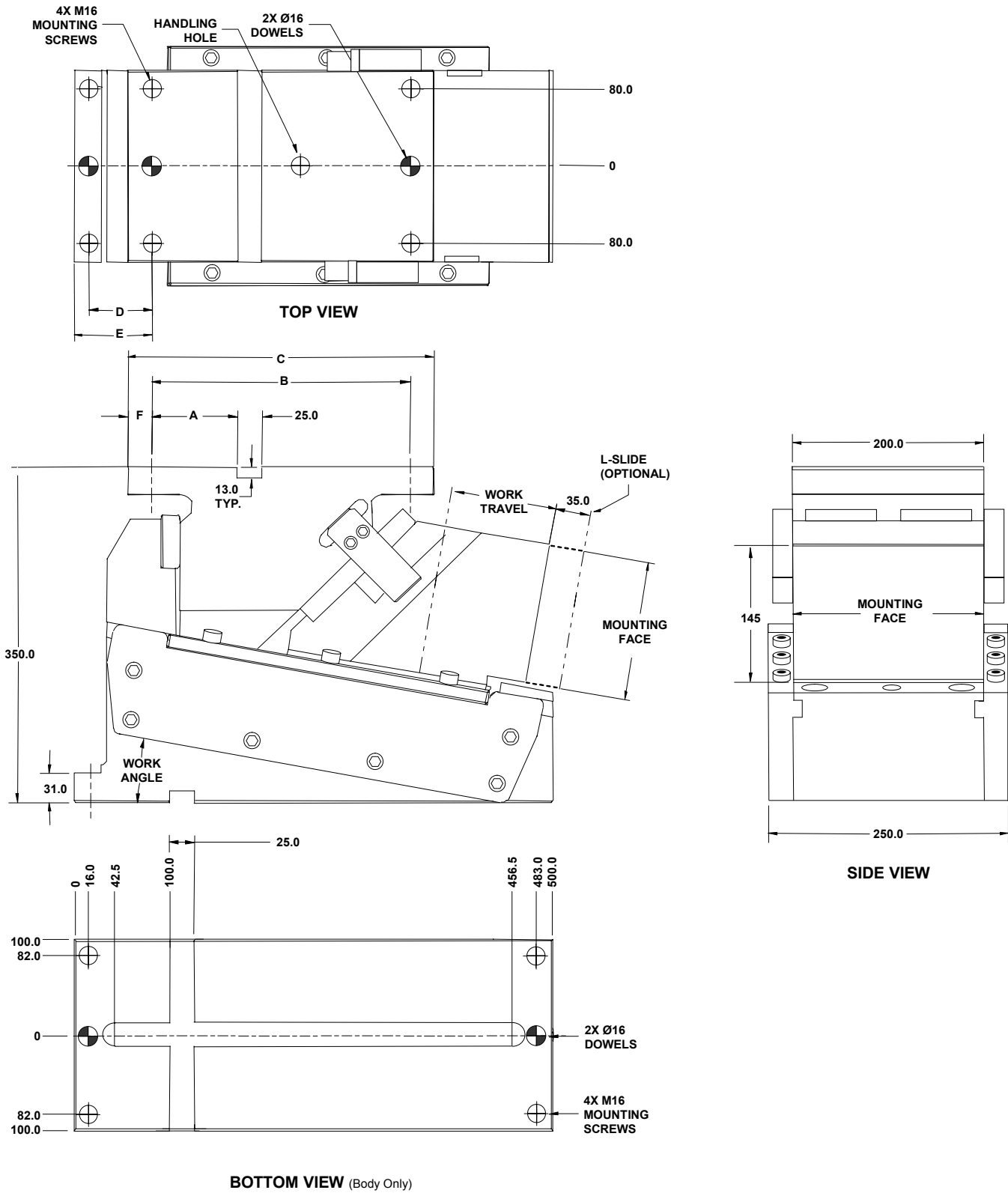

Ask Customer Service for design templates on our website or CD.
Picture not representative of all angles.

*Dowel holes are press fit.
All dimensions are for reference only.
No tolerance is stated or implied.*

Long Reaching (Extra Travel) Die Mount Cam – 200 mm

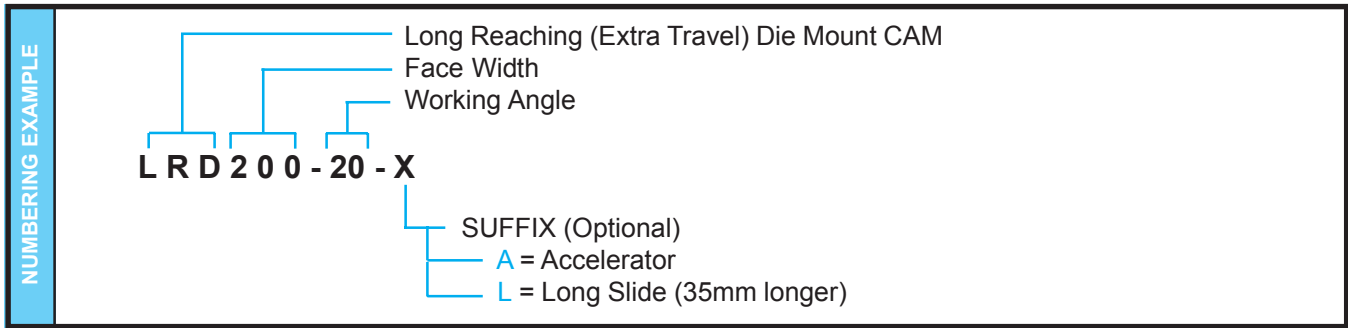

Part Number	Work Angle	Work Travel (mm)	A (mm)	B (mm)	C (mm)	D (mm)	E (mm)	F (mm)
LRD200-00	0	110	90	270	320	65	81	25
LRD200-05	5	110	90	270	320	65	81	25
LRD200-10	10	110	90	270	320	65	81	25
LRD200-15	15	110	30	210	260	125	141	30
LRD200-20	20	110	30	210	260	125	141	30

Max. Work Force (KN/Tons)	Slide Travel (mm)	Mechanical Spring Return Force	Nitrogen Spring Return Force ¹	# Optional Nitrogen Cylinder Pockets ²	Return Force per Nitrogen Spring	Maximum Tooling Weight		Maximum Tooling Envelope ³		Approx. Cam Unit Weight (Kg/Lbs)
		Final (Kg/Lbs) [Three Springs]	Final (Kg/Lbs) [Two Springs]			Weight (Kg/Lbs) Mechanical Spring	Weight (Kg/Lbs) Nitrogen Spring	Protrusion (mm)	Tooling Overhang per side of Slide (mm)	
312/35	110	N/A	680/1498	1	340/749	N/A	20/44	175	45	231/510

¹Nitrogen cylinders do not have a pre-load. Listed nitrogen ratings are at the end of their stroke.

²Three spring pockets built into the cam, two nitrogen springs supplied with nitrogen spring configuration. Spring return calculated based on the standard spring quantity. Customer can add an additional spring for more return force.

³Exceeding the maximum tooling envelope will reduce cam performance and shorten the life of the cam.

Calculation of Load and Stroke

- Θ_1 DRIVING ANGLE OF INCLINATION
- Θ_2 WORKING ANGLE
- F FORCE REQUIRED (PIERCING/TRIMMING/FLANGING FORCE + PAD FORCE + SPRING RETURN FORCE)
- P PRESS FORCE
- V LOAD ON SLIDING SURFACE OF DRIVER
- Q LOAD ON SLIDING SURFACE OF SLIDE
- S WORKING STROKE
- S_1 SPRING STROKE (SLIDE TRAVEL)
- L PRESS STROKE

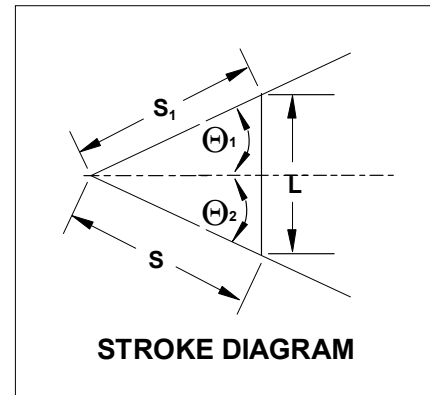
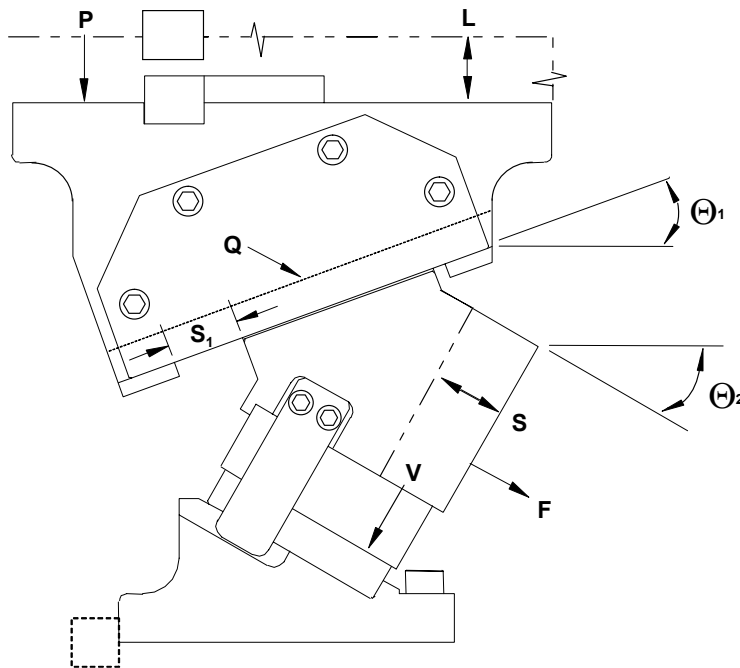

$P = F \times \frac{\cos \Theta_1}{\sin (\Theta_1 + \Theta_2)}$	$L = S \times \frac{\sin (\Theta_1 + \Theta_2)}{\cos \Theta_1}$
$Q = F \times \frac{1}{\sin (\Theta_1 + \Theta_2)}$	$S_1 = S \times \frac{\cos \Theta_2}{\cos \Theta_1}$
$V = F \times \frac{1}{\tan (\Theta_1 + \Theta_2)}$	$S = S \times \frac{\cos \Theta_1}{\cos \Theta_2}$

The IEM Value Proposition

- I. **IEM** is recognized as the leader in manufacturing quality die sets and related products to the global parts forming industry. Our reputation has been built by satisfying customer needs, and we are very strong in the automotive and appliance industries.
- II. **IEM** offers outstanding delivery on a consistent basis. Choosing us as a supplier means that our customers have a competitive advantage in delivering their products to the market.
- III. **IEM** has complex machining capabilities on die sets at several strategically located facilities. Locations throughout the USA means lower shipping costs and allowing **IEM** to machine complex die sets means the customer's machining centers have additional capacity.
- IV. **IEM's** vast breadth of products assures innovative solutions. We strive to address customer problems by utilizing our research and development department as well as other technical professionals.
- V. **IEM** has a technically trained sales force and distributor channels with engineering support. Sales, marketing and engineering professionals are available to support our product lines.

- **Competitive Prices**
- **Reliability and Performance**

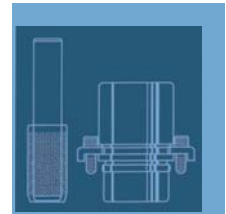
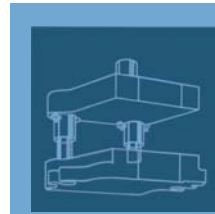

**...A LEADING MANUFACTURER
AND INNOVATOR OF DIE SETS
AND DIE COMPONENTS
SUPPLIED GLOBALLY TO THE
METAL FORMING INDUSTRY...**

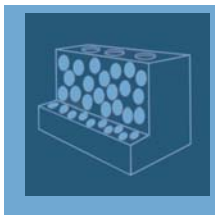
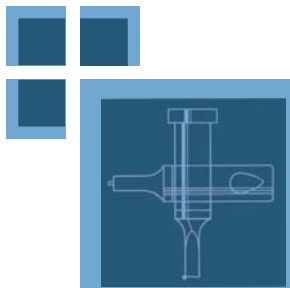

- **High Quality Design & Construction**
- **Outstanding Service & Support**



AERIAL & DIE MOUNT CAMS CATALOG



Distributed by:

www.dandy.com
cams@dandy.com

WITHIN THE USA & CANADA
CALL: 800-243-2659
FAX: 800-833-2659

OUTSIDE THE USA & CANADA
CALL: 001-216-489-7816
FAX: 001-216-553-6842