

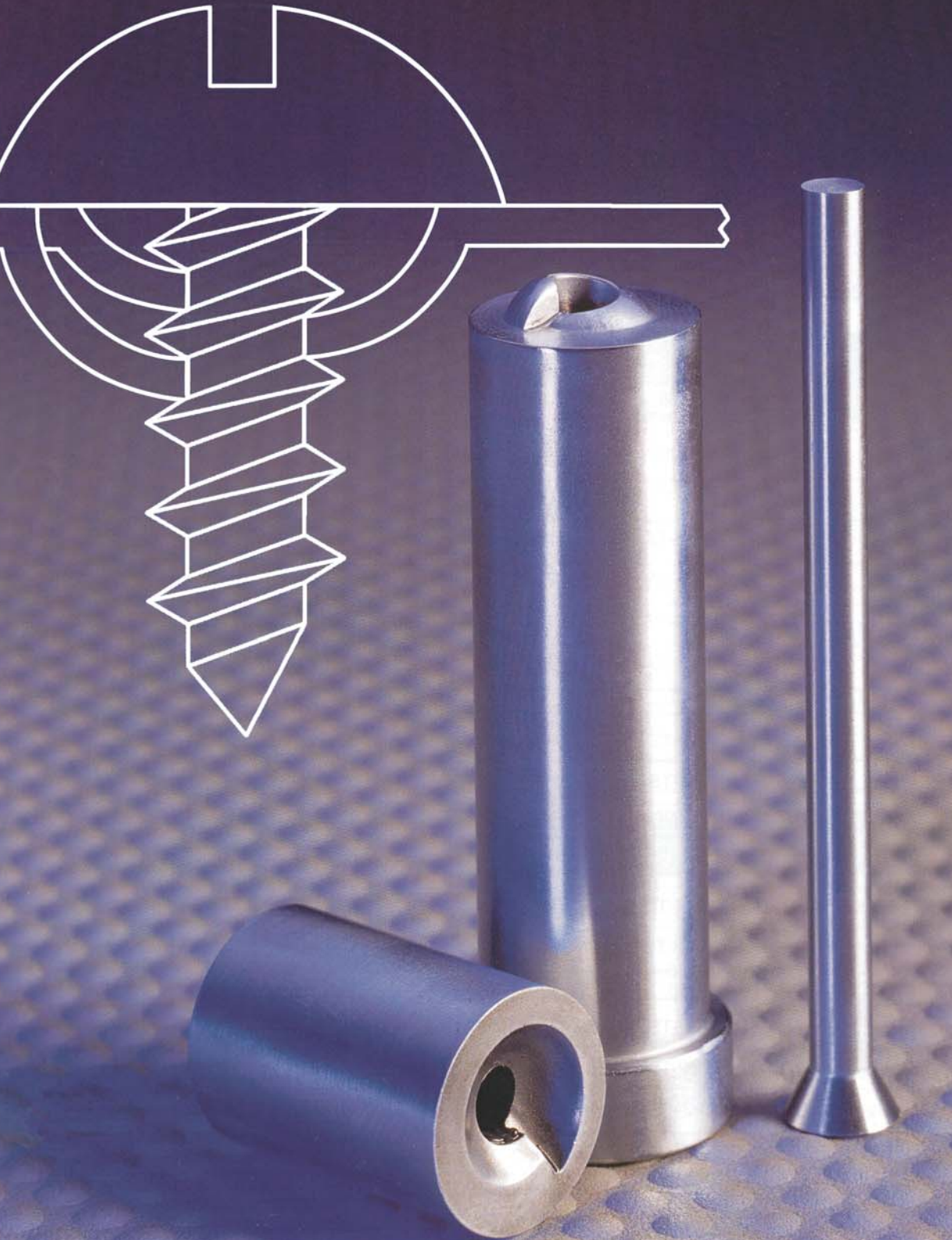

Punchrite®

Anchor Danly

THREAD FORMS



BALL LOCK AND BASIC TOOLS

- ◆ FORM A SELF-LOCKING FASTENER WITH YOUR DIE TOOLING
- ◆ IDEAL FOR THINNER MATERIALS
- ◆ UNIQUE DESIGN USES METAL TENSION TO LOCK SCREWS IN PLACE
- ◆ SPEEDS PRODUCTION, CUTS COSTS
- ◆ STANDARD FORMS FOR SCREW TYPE AND THREADS AVAILABLE



THREAD FORMS

BALL LOCK AND BASIC TOOLS

How to Order:

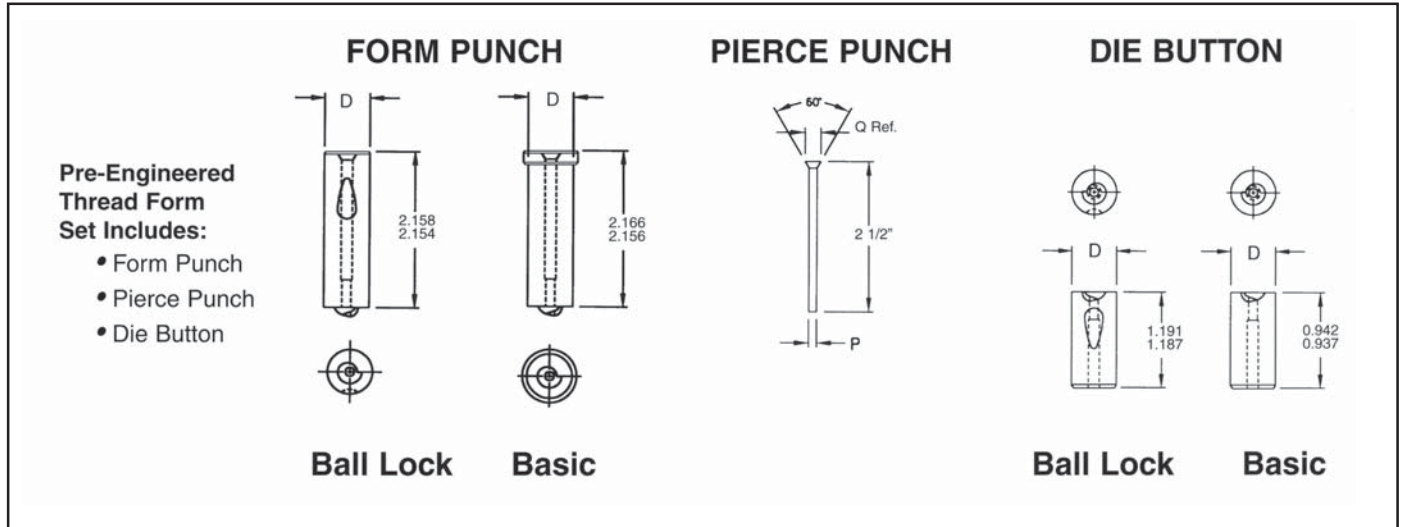
Please specify Catalog Number



Screw Type	Thread Size	Form Set		Form Punch		Pierce Punch	Die Button		Diameter D
		Ball Lock	Basic	Ball Lock	Basic		Ball Lock	Basic	
		Catalog Number	Catalog Number	Catalog Number	Catalog Number		Catalog Number	Catalog Number	
 A	6-18	6-18-LBTS	6-18-TS	803-LBTP	TP-6A	8031-P	813-LBTD	TD-6A	3/8
	8-15	8-15-LBTS	8-15-TS	804-LBTP	TP-8A	8042-P	814-LBTD	TD-8A	1/2
	10-12	10-12-LBTS	10-12-TS	824-LBTP	TP-10A	8243-P	834-LBTD	TD-10A	1/2
	12-11	12-11-LBTS	12-11-TS	845-LBTP	TP-12A	8454-P	855-LBTD	TD-12A	5/8
	14-10	14-10-LBTS	14-10-TS	865-LBTP	TP-14A	8655-P	875-LBTD	TD-14A	5/8
	20-9	20-9-LBTS	20-9-TS	886-LBTP	TP-20A	8866-P	896-LBTD	TD-20A	3/4
 B AB	6-20	6-20-LBTS	6-20-TS	1803-LBTP	TP-6B	18031-P	1813-LBTD	TD-6B	3/8
	8-18	8-18-LBTS	8-18-TS	1804-LBTP	TP-8B	18042-P	1814-LBTD	TD-8B	1/2
	10-16	10-16-LBTS	10-16-TS	1824-LBTP	TP-10B	18243-P	1834-LBTD	TD-10B	1/2
	12-14	12-14-LBTS	12-14-TS	1845-LBTP	TP-12B	18454-P	1855-LBTD	TD-12B	5/8
	1/4-14	1/4-14-LBTS	1/4-14-TS	1865-LBTP	TP-14B	18655-P	1875-LBTD	TD-1/4B	5/8
	5/16-12	5/16-12-LBTS	5/16-12-TS	1886-LBTP	TP-20B	18866-P	1896-LBTD	TD-5/16B	3/4
 C (Machine Screws)	6-32	6-32-LBTS	6-32-TS	2803-LBTP	TP-6C	28031-P	2813-LBTD	TD-6C	3/8
	8-32	8-32-LBTS	8-32-TS	2804-LBTP	TP-8C	28042-P	2814-LBTD	TD-8C	1/2
	10-24	10-24-LBTS	10-24-TS	2824-LBTP	TP-10C	28243-P	2834-LBTD	TD-10C	1/2
	10-32	10-32-LBTS	10-32-TS	2845-LBTP	TP-10CF	28454-P	2855-LBTD	TD-10CF	5/8
	1/4-20	1/4-20-LBTS	1/4-20-TS	2865-LBTP	TP-1/4C	28655-P	2875-LBTD	TD-1/4C	5/8
	5/16-18	5/16-18-LBTS	5/16-18-TS	2886-LBTP	TP-5/16C	28866-P	2896-LBTD	TD-5/16C	3/4

THREAD FORMS

THREAD FORM DATA

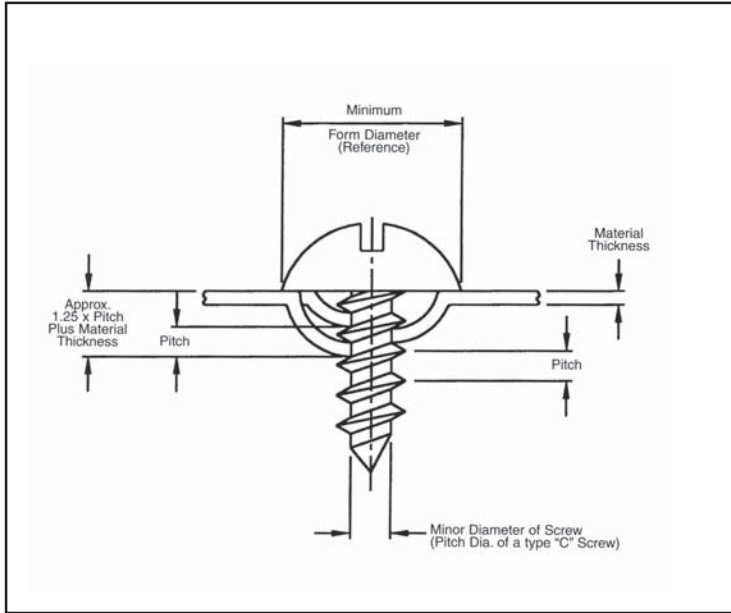

Thread Size	Material Thickness	Pitch (Ref.)	Max. Minor Diameter of Screw	Minimum Form Diameter
TYPE "A" SCREWS				
6 - 18	.020 - .030	0.0556	0.102	0.276
8 - 15	.025 - .040	0.0667	0.123	0.306
10 - 12	.030 - .045	0.0833	0.133	0.352
12 - 11	.035 - .054	0.0909	0.162	0.406
14 - 10	.038 - .060	0.1000	0.185	0.442
20 - 9	.050 - .060	0.1111	0.234	0.556
TYPE "B" AND "A B" SCREWS				
6 - 20	.020 - .030	0.0500	0.104	0.208
8 - 18	.020 - .030	0.0556	0.122	0.296
10 - 16	.020 - .030	0.0625	0.141	0.374
12 - 14	.030 - .040	0.0714	0.164	0.400
1/4 - 14	.030 - .040	0.0714	0.192	0.400
5/16 - 12	.030 - .040	0.0833	0.244	0.552
TYPE "C" SCREWS (MACHINE SCREWS)				
6 - 32	.010 - .020	0.0313	0.118	0.290
8 - 32	.010 - .020	0.0313	0.144	0.324
10 - 24	.015 - .025	0.0417	0.163	0.370
10 - 32	.010 - .020	0.0313	0.170	0.348
1/4 - 20	.020 - .030	0.0500	0.218	0.478
5/16 - 18	.020 - .030	0.0556	0.276	0.490

DIE BUTTONS

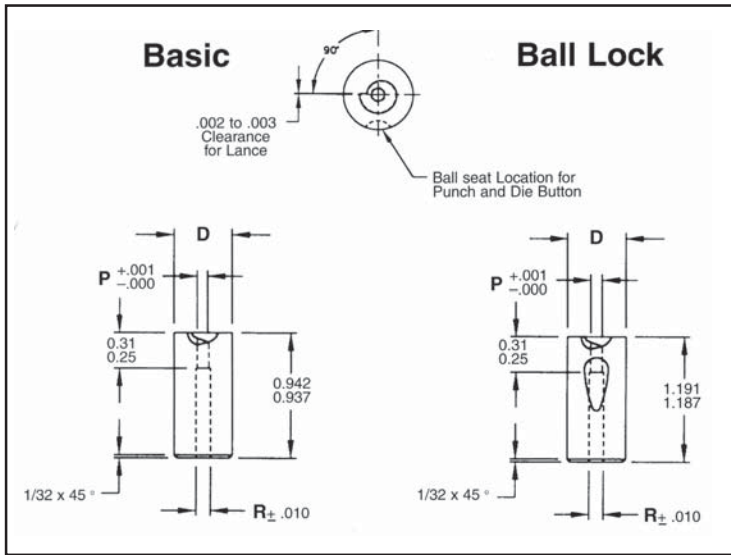

Body Diam. D Norm.	Ball Lock Body Diam. D Actual	Ball Size	Press Fit Body Diam. D Actual	Thread Size	P Diam.	R Diam.
3/8	.3748/.3746	1/4	.3758/.3755	6-18	0.108	0.141
				6-20	0.111	0.141
				6-32	0.118	0.136
1/2	.4998/.4996	5/16	.5008/.5005	8-15	0.125	0.166
				8-18	0.125	0.166
				8-32	0.144	0.156
				10-12	0.134	0.173
				10-16	0.142	0.173
				10-24	0.164	0.177
5/8	.6248/.6246	5/16	.6264/.6260	10-32	0.171	0.188
				12-11	0.162	0.196
				12-14	0.162	0.196
				14-10	0.187	0.228
				1/4-14	0.192	0.228
				1/4-20	0.218	0.234
3/4	.7498/.7496	3/8	.7514/.7510	20-9	0.238	0.281
				5/16-12	0.245	0.281
				5/16-18	0.277	0.290

PUNCHES

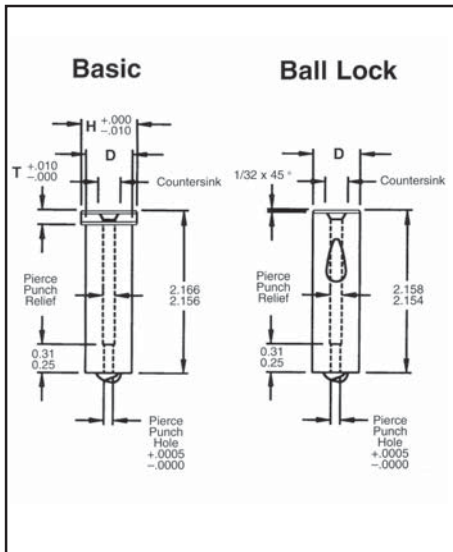

Shank Diam. D Norm.	Ball Lock Only		Basic Only			Thread Size	Form Punch			Pierce Punch	
	Shank Diam. D Actual	Ball Size	Shank Diam. D Actual	Head Diam. H	Thick. T		Hole Diam.	Relief Diam.	Sink Diam. C	Diam. P	Diam. Q
3/8	.3748/.3746	1/4	.3755/.3752	1/2	3/16	6-18	.1045	0.116	0.188	0.104	0.188
						6-20	.1075	0.120	0.193	0.107	0.193
						6-32	.1155	0.125	0.208	0.115	0.208
1/2	.4998/.4996	5/16	.5005/.5002	5/8	3/16	8-15	.1205	0.136	0.217	0.120	0.217
						8-18	.1205	0.136	0.217	0.120	0.217
						8-32	.1415	0.156	0.255	0.141	0.255
						10-12	.1285	0.141	0.231	0.128	0.231
						10-16	.1385	0.150	0.250	0.138	0.250
						10-24	.1605	0.172	0.289	0.160	0.289
5/8	.6248/.6246	5/16	.6255/.6252	3/4	1/4	10-32	.1675	0.187	0.302	0.167	0.302
						12-11	.1565	0.166	0.282	0.156	0.282
						12-14	.1585	0.170	0.286	0.158	0.286
						14-10	.1805	0.191	0.325	0.180	0.325
						1/4-14	.1885	0.201	0.340	0.188	0.340
						1/4-20	.2135	0.234	0.385	0.213	0.385
3/4	.7498/.7496	3/8	.7505/.7502	7/8	1/4	20-9	.2315	0.242	0.418	0.231	0.418
						5/16-12	.2415	0.250	0.436	0.241	0.436
						5/16-18	.2725	0.281	0.492	0.272	0.492

THREAD FORMS

EXCESSIVE MATERIAL – THICKNESS RECOMMENDED SOLUTIONS

1. Revise screw thread specifications (preferred).
Substitute a screw with a “pitch” suitable for material thickness.
2. Enlarge center hole by enlarging pierce punch size.

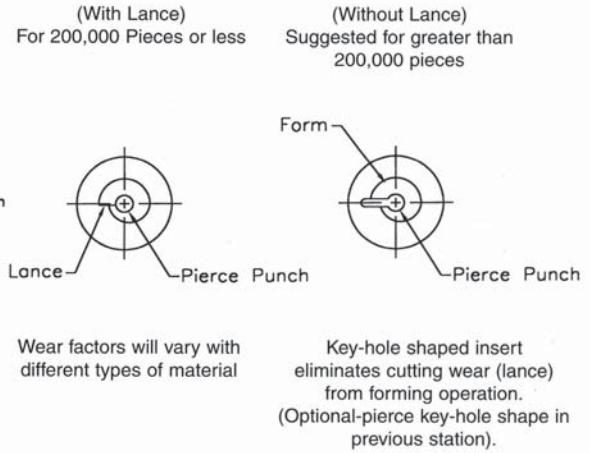
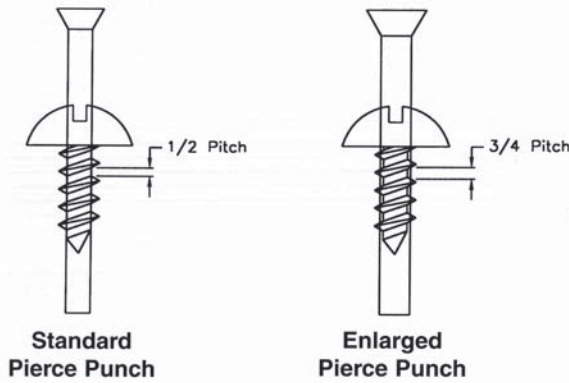

3. Thin material in a previous station.

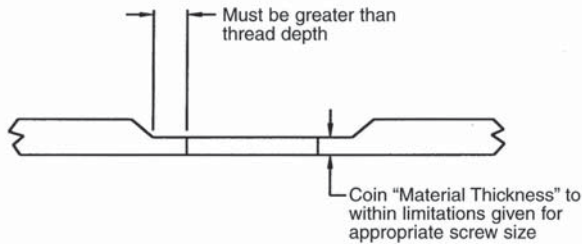

For design flexibility, inverted form is available.

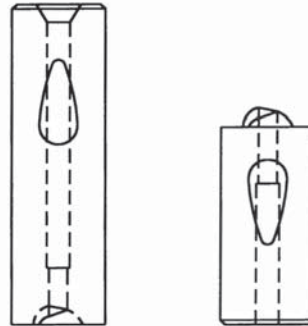

Anchor Danly

16065 Industrial Lane
Cleveland, OH 44135

www.anchorandaly.com
punchproducts@anchorandaly.com

WITHIN THE USA & CANADA
CALL: 800-232-6592
FAX: 800-432-6594

OUTSIDE THE USA & CANADA
CALL: 001-216-898-4399
FAX: 001-216-898-4358