

C.E. TOOLING

Section **8**

Pricing Booklet



Reference Section 1 For Technical Information

SALVAGNINI TOOLING STYLE *Type III*



For S2, S4.25, S4.3, S4.4,
Pluri,
and compatible machine

Salvagnini Type III Style Tools

We are still developing this product line, so are continually adding products.

We emphasize our Salvagnini style tooling towards offering a better alternative for special shapes, cluster, and form tools.

Tool Description	Delivery Days
S1, S4, S6	3- 8 Work Days
S5, S8, S9, SA, P5	12 Work Days
PO, P3, P9 Punch & Die Only	5 Work Days
P0, P3, P9 Punch Assembly or Guide only	10-15 Work Days
S5	

Expedite services available

10 STANDARD SHAPES

RT Rectangles • SQ=Square • OB=Obround • SD=Single-D • DD=Double-D • LD=Long-D • EQ=Equilateral • OC=Octagon • HX=Hexagon • QD=Quad-D Add \$10 per set to standard price for LD & EQ

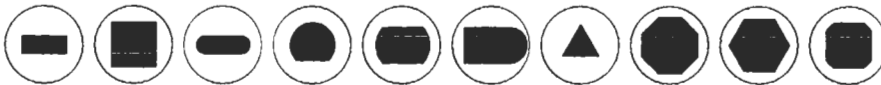

Salvagnini Shape Codes: Round=01, Square=2Q, Single-D=41, Double-D=42, Rectangle=2R, Rect-w/4rAD=43, Obround=08, Hexagon=45, Octagon=49, SP50=11(+k0,k1,k2,k3=std dim), SP20=12(t0,t1,t2,t3=std dim.), SP44=6a,b,c

SPECIAL SHAPES



Add 25% to set price for Clearance of .003(.08mm) & <

ADDITIONAL COSTS FOR NON-STANDARD OPTIONS

	RADIUS	CHAMFER	RADIUS or 45°CHAMFERS + \$.00 per corner	
			PUNCHES	Corners 1-3 X # 4(all)
With Length under 1.625 and any size Radius or Chamfer			# X \$10.00	\$10.00
With Length over 1.625 & .032 maximum Radius or Chamfer			# X \$10.00	\$30.00
With Length over 1.625 and Radius or Chamfer over .032(.8mm)			# X \$15.00	\$40.00
Add On To All DIES any size Radius or Chamfer			# X \$10.00	\$10.00
No Extra Charge for STRIPPERS or GUIDES When Ordered With Set				

Shapes on Angles other than 90° Increments

Punch: 7 ton Sta. + \$45.00
12 ton sta. + \$60.00
26 ton Sta. + \$90.00
Dies 7 ton Sta. + \$25.00
12 ton sta. + \$45.00
26 ton Sta. + \$90.00

Sheet Protection Brushes Used on 7 ton Loaders, dies & strippers of 26 ton and some 12 ton PU, PR, P2R

Code	D	d
3153010048	4.5	3
2121092A4	8	5
3153010004	13	10

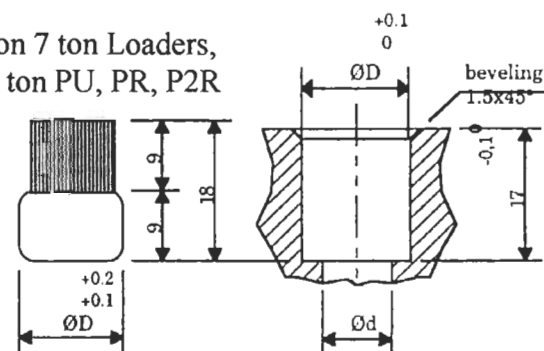



Salvagnini Style PUNCH HEADS

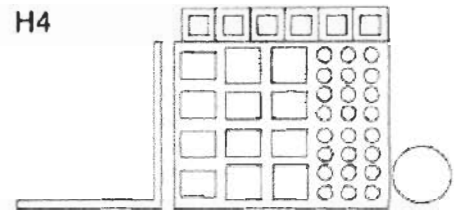
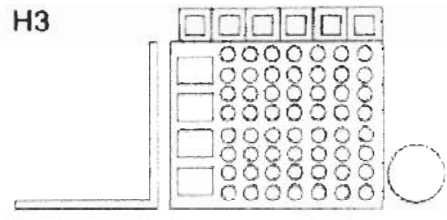
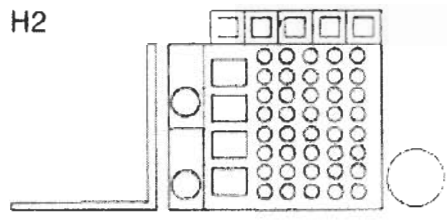
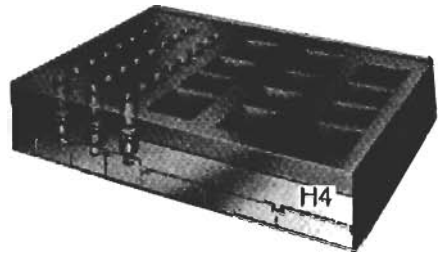
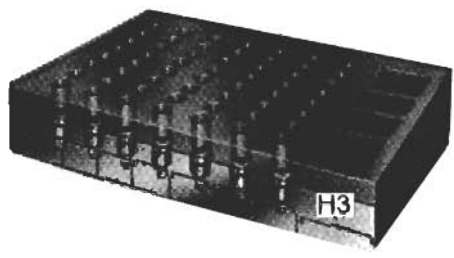
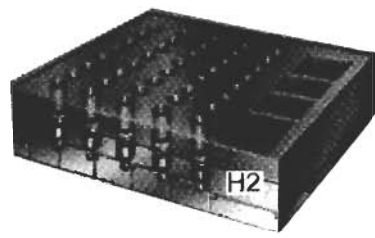

Configuration	H2	H3	H4
7 ton presses - Max tool \varnothing 33 mm	40	56	24
26 ton presses - Max tool 90x70 mm	4	4	12
Optional fixed presses for punching (12 tons) or embossing (8 tons) - Max tool \varnothing 60 mm	5	6	6
Optional double rotary presses for punching (12 tons) - Max tool \varnothing 60 mm	2	3	3

BU31-BU35 are optional presses commonly used for embossing (forming). Upper cylinder has 8 ton force, lower has 7 tons. Max. depth of upward stroke is 16mm, down is 7mm.

Pluri or H2 Head Config.

	BU31	BU32	BU33	BU34	BU35
24 (3.0) 90 X 90 SA F-__	60	56	52	48	44
	59	55	51	47	43
23 (3.0) 70 X 90 SA E-__	58	54	50	46	42
	57	53	49	45	41
22 (3.0) 70 X 90 SA E-__	20	16	12	8	4
	19	15	11	7	3
21 (3.0) 90 X 90 SA F-__	18	14	10	6	2
	17	13	9	5	1

?Double Rotating punching unit P2R36 12 ton

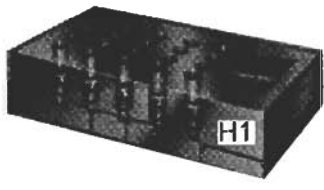
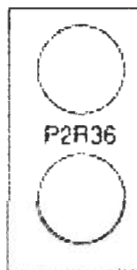



Salvagnini Style Type III 7 Ton 33mm Positions 1-20,

Small Sizes
 <.093+30%
 <.062 +50%,
 <.046 + 100%

Grind Life:
 Punch & Dies
 OEM recommends
 .118/3,0mm

PUNCH CHUCKS
 0a (*A-SA0aPC)
 0b (*A-SA0bPC)

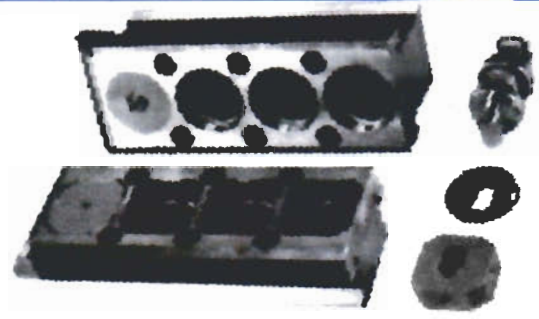
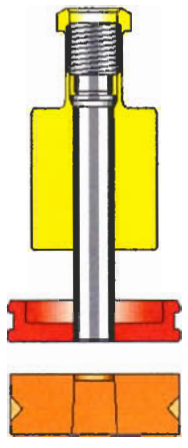
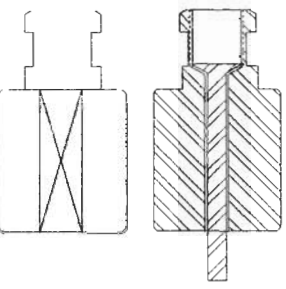

Square Clutch Shown, some symmetrical shapes such as rounds and squares, have Rectangle

SIZE 0a .031-.236 (.8-6,mm)
SIZE 0b .236-.413 (6,-10,5mm)
 Ref. Compatible for use in Mate® or Pass Chucks

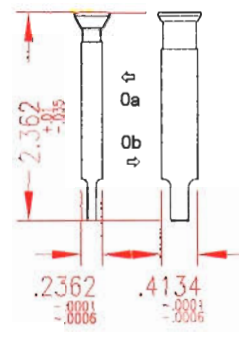

Ref. Compatible for use in Salvagnini Chucks

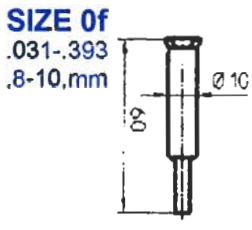

STRIPPER

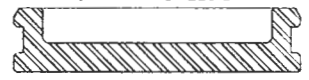

DIE

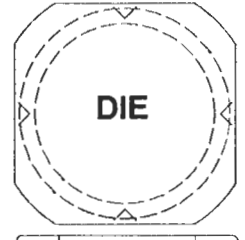

	DESCRIPTION	Range Diagonally	Salvagnini Part #	Mate Part # =shape	Pass Part # =shape	C.E. Part# *R-round S-shape	PRICE ROUND	PRICE SHAPE
Mate® Style compatible	SET Punch Insert 0a Stripper & Die	.0315-.236"	N/A	PAPA0A S6PA_A DAPA_0	S3P1_1 S3 A1-5_1 S3M3-5M1_1	SA0a-PDS*		
	Punch INSERT 0a HSS	.8-6,0mm	N/A	PAPA0A	S3P1_1	SA0a-P.*		
	SET Punch Insert 0b Stripper & Die	.0315-.413"	N/A	PAPB0ADS 6PB0A DAPB00	S3P1_2 S3 A1-5_1 S3M3-5M1_1	SA0b-PDS-*		
	Punch INSERT 0b HSS	.8-10,5mm	N/A	PAPB0A	S3P1_2	SA0b-P.*		
S1	SET Punch Insert 0a Stripper & Die	.0315-.393" .8-10mm		N/A		SA0fPDS		
	Punch INSERT 0f HSS		PS1-*	N/A	S3 P2_2-3	SA0f-P.*		
	DIE D2 18%chrome		DS4-*	DAPA-C_0	S3M1-5M1_1	SAC-D.*		
S4	SET Solid Punch Punch, Stripper & Die	.0315-1.299 ,8-33mm		PAPC_A S6PA-C#A DAP_A-C#0	S3S1-5D1 S3 A1-5_1 S3M3-5M1_1	SAC-PDS-*		
	PUNCH SOLID HSS		PS4-*	PAPC_A	S3S1-5_1	SAC-P.*		
	STRIPPER		SS4-*	S6PA-C_A	S3A1-5_1	SAC-S.*		
	DIE D2 18%chrome		DS4-*	DAPA-C_0	S3M1-5M1_1	SAC-D.*		



Salvagnini Style Type III 7 Ton 33mm Positions 1-20, 41-76 Fully Guided Perforating Assembly

Salvagnini P0 Style – Compatible

Sharpening Life: Round: Punch .118 3,0mm Die .06" 1,5mm
Shaped: Punch .079 2,0mm Dies .06" 1,5mm

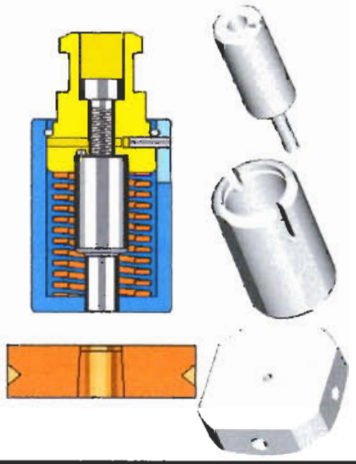

	DESCRIPTION	Range Diagonally	Sal- vagnini Part #	Pass #	C.E. Code * = R-round S-shape	PRICE ROUND	PRICE SHAPE
P0	SET Punch Assembly & Die	0315- .393" .8 - 10mm			SA0-PAD-*		
	Punch ASSEMBLY		UP0-*		SA0-PA-*		
	PUNCH HSS=M2		PP0-*	PAS0_A_	SA0-P-*		
	Punch GUIDE		BP0-*	S2PN_A	SA0-G-*		
	DIE D2 18%chrome		DP0-*	DAPC_0	SAC-D-*		
Tang Assembly Includes spring, washer, draw bolt, and retaining ring					SATA-0		

Salvagnini P3 Style – Compatible

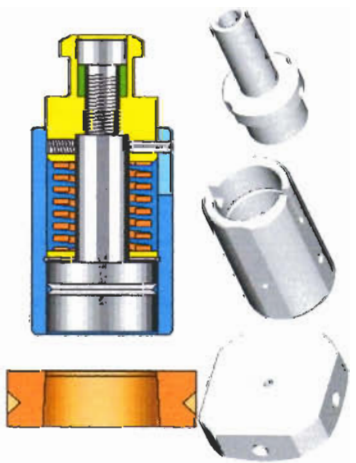

	DESCRIPTION	Range Diagonally	Sal- vagnini Part #	Pass #	C.E. Code * = R-round S-shape	PRICE ROUND	PRICE SHAPE
P3	SET Punch Assembly & Die	0315- 1.023" .8 - 26mm	UP3-*		SA3-PAD-*		
	Punch ASSEMBLY		UP3-*		SA3-PA-*		
	PUNCH HSS=M2		PP3-*	PAS0_A_	SA3-P-*		
	Punch GUIDE		BP3-*	S2PN_A	SA3-G-*		
	DIE D2 18%chrome		DP3-*	DAPC_0	SAC-D-*		
Tang Assembly Includes spring, washer, draw bolt, and retaining ring					SATA-3		

Salvagnini P9 & Mate® Style – Compatible

Sharpening Life: Round: Punch .118 3,0mm Die .06" 1,5mm
Shaped: Punch .079 2,0mm Dies .06" 1,5mm

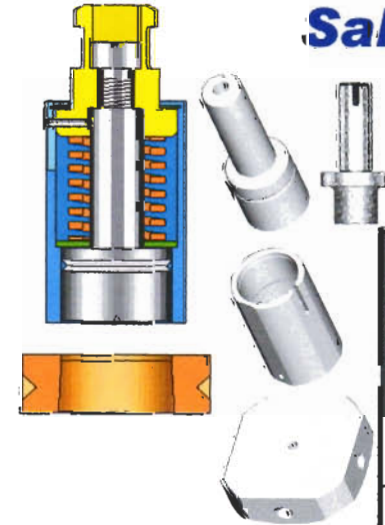

	DESCRIPTION	Range Diagonally	Sal- vagnini Part #	Ref. Mate Part #	C.E. Code * = R-round S-shape	PRICE ROUND	PRICE SHAPE
P9	SET Punch Assembly & Die	0315- 1.023" .8 - 26mm			SAM-PAD-*		
	Punch ASSEMBLY		UP9-*		SAM-PA-*		
	PUNCH HSS=M2		PP9-*	PAS0_A_	SAM-P-*		
	Punch GUIDE		BP9-*	S2PN_A	SAM-G-*		
	DIE D2 18%chrome		DP9-*	DAPC_0	SAC-D-*		
Tang Assembly Includes spring, washer, draw bolt, and retaining ring				VCPCS	SATA-M		



Large Station 26 Ton Tools Positions 21-24

PUNCH SUPPORT
40M09727 shown

Specify orientation of shapes
"Y" Axis or "X" Axis

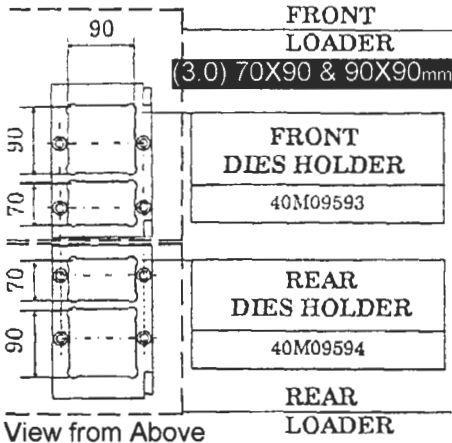

View from Above

70X90 Square 2"X2"
Punch Shown →

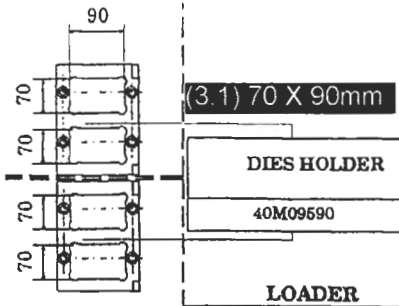
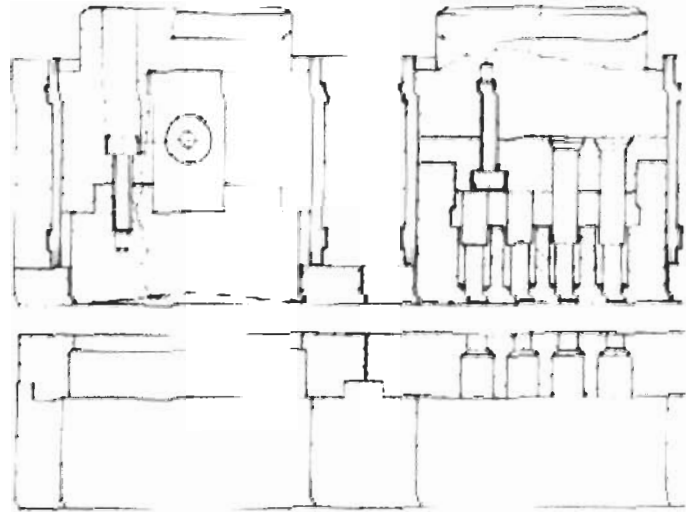

View from Above

PUNCH

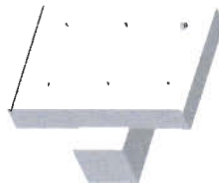

STRIPPER



DIE



(3.1) 70 X 90mm Positions 21, 22, 23, 24

Only for machines that DO NOT have a 90X90 Head.

PUNCH SUPPORT: \$
Code= SA-40M09727 Ref. Mate®=VSPES

Sheet Protection Brushes
*A3153010004
Package of 16
\$50.00

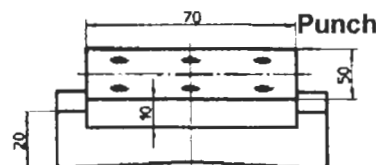
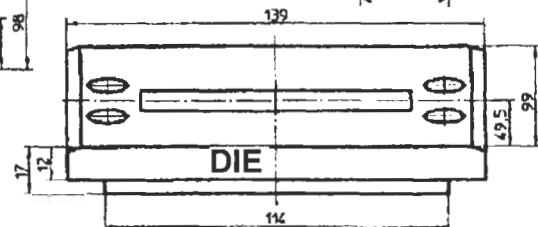
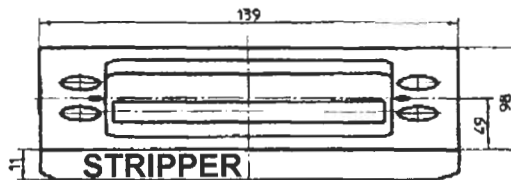
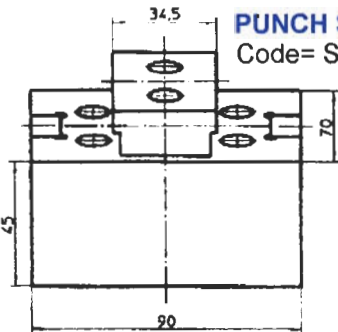
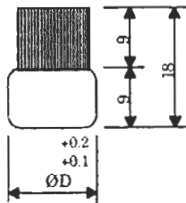

S8	SET		Range	Salvagnini	Mate #	Pass #	C.E. Part #	PRICE	PRICE
	Punch Stripper & Die		X = ↔ Y = ↓	Part #	_shape	_shape	*=R-round S-shape	ROUND	SHAPE
			2.755X3.543	US8-*			SAEPDS-*		
	PUNCH HSS=M2	70X90mm		PS8-*	PAPLE_A	SX S6 _1	SAE-P-*		
	STRIPPER	Max. Dim.		SS8-*	S6Q E_A	SX A6 _1	SAQ-S-*		
	DIE D2 18%chrome	↔X=90mm ↑Y=70mm		DS8-*	D2Q E_O	SX M6 _1	SAQ-D-*		



Large Station 26 Ton Tools Positions 21-24

(3.0) 70 X 90mm Positions 22&23 Station sits between 90X90 Only for machines also having a 90X90 Head.

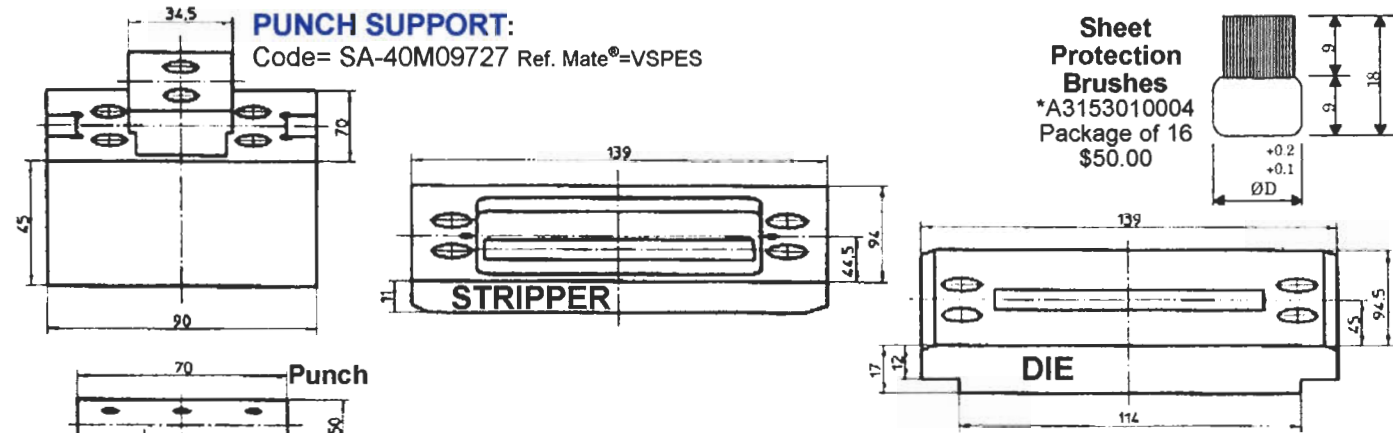

		Range X = ↔ Y = ↑	Salvagnini Part #	Mate Part # _shape	Pass Part # _shape	C.E. Code *=R-round S-shape	PRICE ROUND	PRICE SHAPE .093/2,3&>
S9	SET Punch Stripper & Die	2.755 X 3.543		PAP E_A S6P E_A D2P E_A	SX S6 _1 SX A6 _1 SX M6 _1	SA E-PDS-*		
	PUNCH HSS=M2	70X90mm Max. Dim.	PS9-*	PAPC_A	SX S6 _1	SA E-P-*		
	STRIPPER	↔X =90mm ↑Y=70mm	SS8-*	S6PE_A	SX A6 _1	SA E-S-*		
	DIE D2 18%chrome		DS8-*	D2PE_O	SX M6 _1	SA E-D-*		

(3.0) 90 X 90mm Positions 21&24 Station sits between 90X90 Only for machines also having a 90X90 Head.

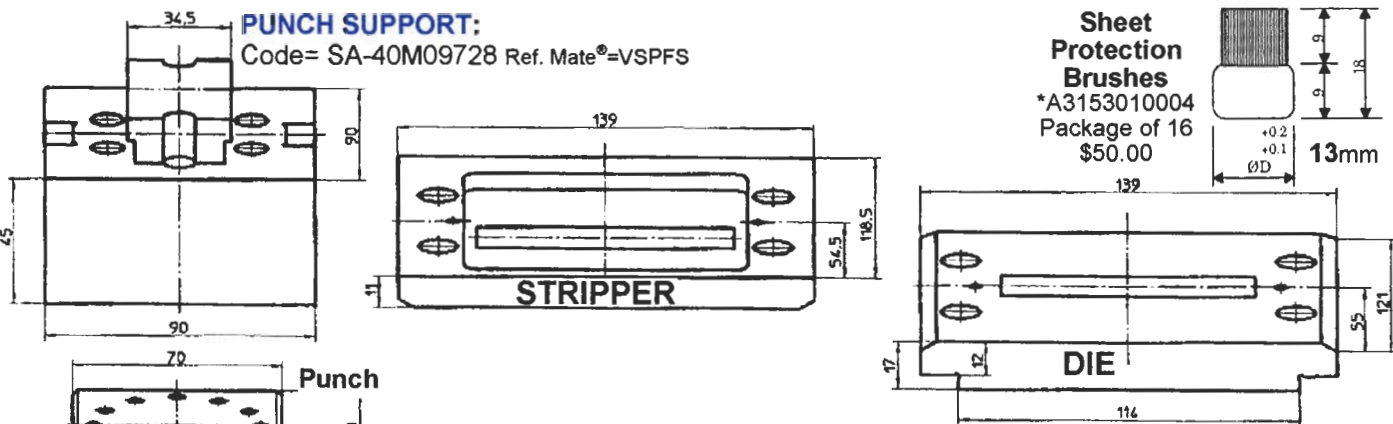

		Range X = ↔ Y = ↑	Ref. Salvagnini Code	Ref. Mate # _shape	Ref. Pass # _shape	C.E. Code *=R-round S-shape	PRICE ROUND	PRICE SHAPE .093/2,3&>
SA	SET Punch Stripper & Die	3.543 X 3.543	40M09### 40M09###	PAP F_A S6P F_A D2P F_A	SX S7 _1 SX A7 _1 SX M7 _1	SA F-PDS-*		
	PUNCH HSS=M2	90X90mm Max. Dim.		PAPF_A	SX S7 _1	SA F-P-*		
	STRIPPER	↔X =90mm ↑Y=90mm	40M09###	S6PF_A	SX A7 _1	SA F-S-*		
	DIE D2 18%chrome		40M09###	D2PF_O	SX M7 _1	SA F-D-*		



Salvagnini Style: Optional 12 Ton 42,4mm

P5 Holder Sta. X

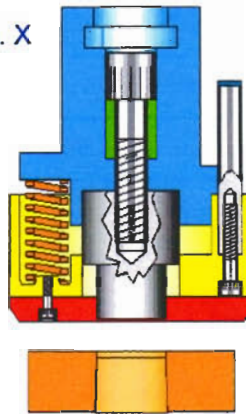
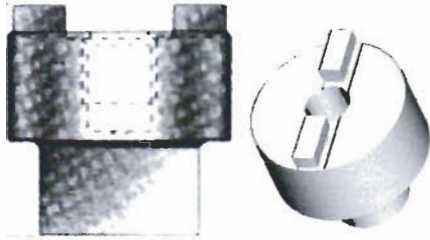

DIE

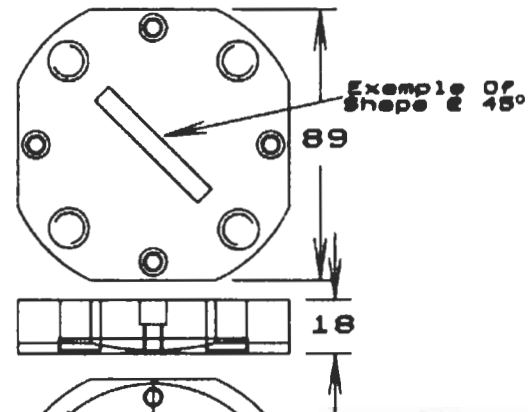

.276
(7.0)

**Stripper
Sta. X P5**

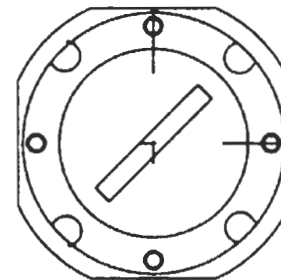

**Sheet Protection Brushes
*A315301004**

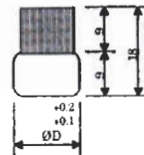

		Range X = ↔ Y = ↓	Salvagnini Part #	Mate Part # =shape	Pass Part # =shape	C.E. Part # *R-round S-shape	PRICE ROUND	PRICE SHAPE .093/2,3&>
P5	SET Sta. X Punch Stripper & Die	42,4/1.669 Max. Dim.	UP5-*	PAP D_A S6P D_A D2P D_A	SX S1_1 SX A1_1 SX M1_1	SA X-PDS-*		
	PUNCH HSS=M2		PP5-*	PAPD_A	SX S1_1	SA X-P-*		
	STRIPPER		BP5-*	S6PD_A	SX A1_1	SA X-S-*		
	DIE D2 18%chrome		DP5-*	D2PD_O	SX M1_1	SA X-D-*		



Salvagnini Style: Optional 12 Ton 60mm

S6 Auto Index Punch Sta.D

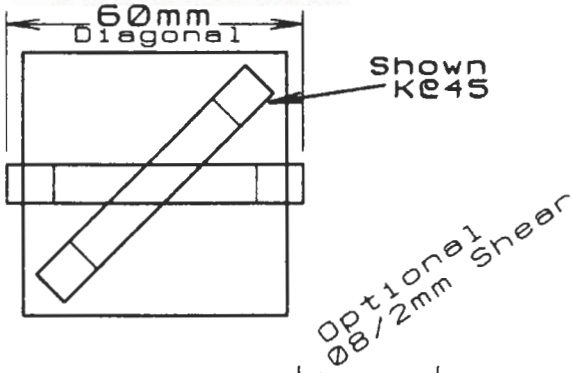

S6 Sta. D

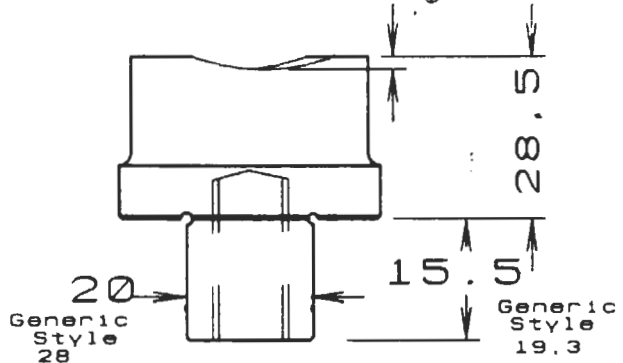
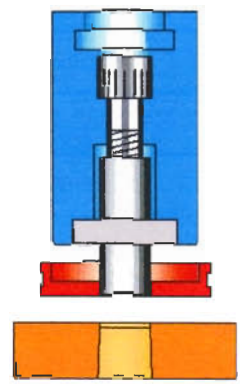

DIE

S6 Auto Index DIE Sta.D

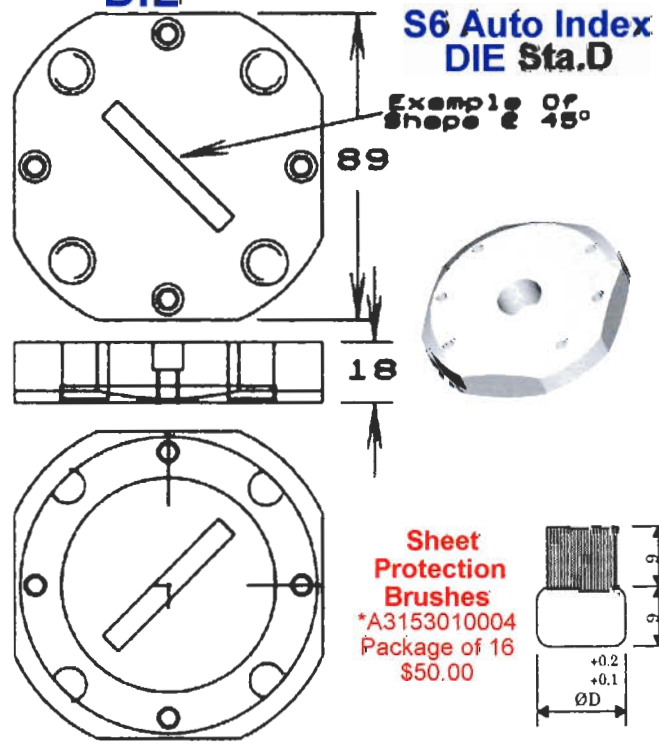

A.I. STRIPPER

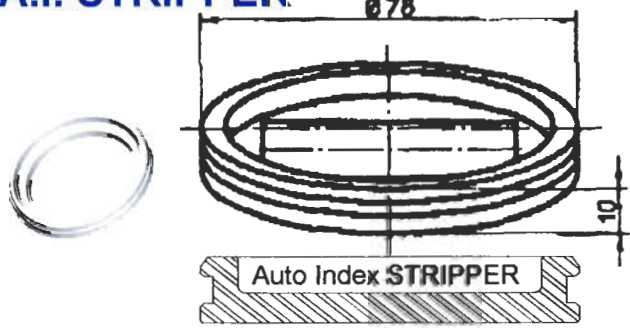

Sheet Protection Brushes
 *A3153010004
 Package of 16
 \$50.00

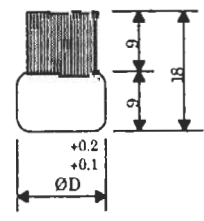

		Range X ↔ Y ↓	Salvagnini Part #	Mate Part # _shape	Pass Part # _shape	C.E. Part # *_R-round *_S-shape	PRICE ROUND	PRICE SHAPE
S6	SET Sta. D Punch Stripper & Die	60mm/2.362 Max. Dim.	US6-*			SA D-PDS-*		
	PUNCH HSS=M2	60 X 20 2.362X.78"7	PS6-*	IPAPX_A		SA D-P-*		
	STRIPPER	Rectangle →X=60mm ↑Y=20mm	SS6-*	S6PX_A		SA D-D-*		
	DIE D2 18%chrome		DS6-*	ID2PD_O	SX M1 _1	SA D-D-*		



Salvagnini Style: Special Application Tools

EI Emboss Station, Optional Some positions can be fitted for low profile forming operations (max. FH=6,5mm) where no scrap is generated.

Position 30-35 BU Emboss Option Double action 8+7 ton press Forming applications (Max FH=16mm)

Form Up EI, 7 Ton Position

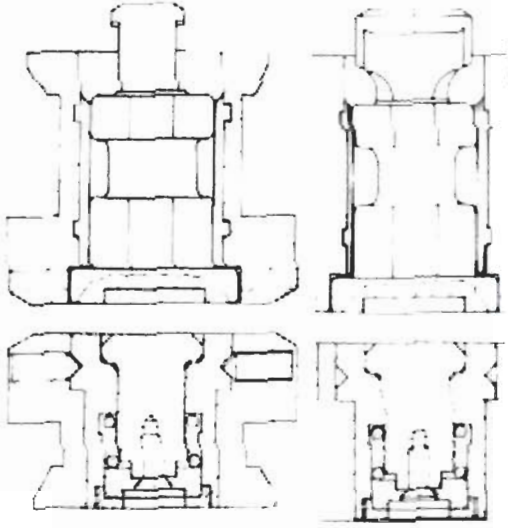

Standard 7 Ton Position

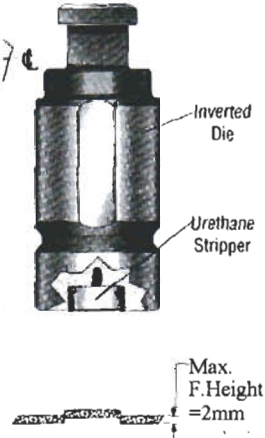

Large 26ton Station

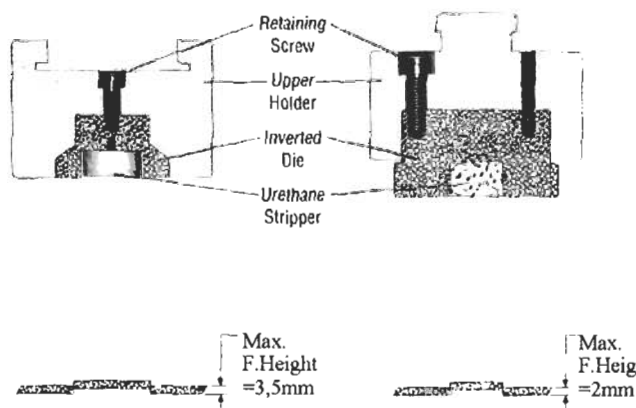

BU Embossing Tool for Upward Forming

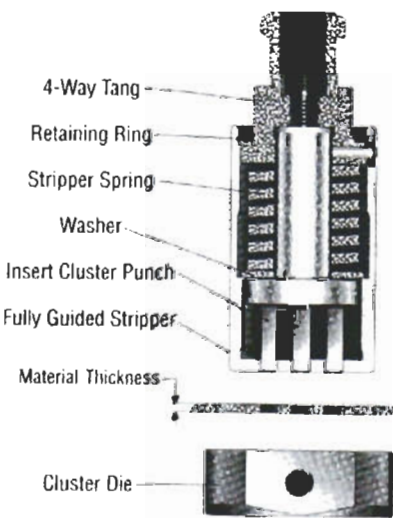
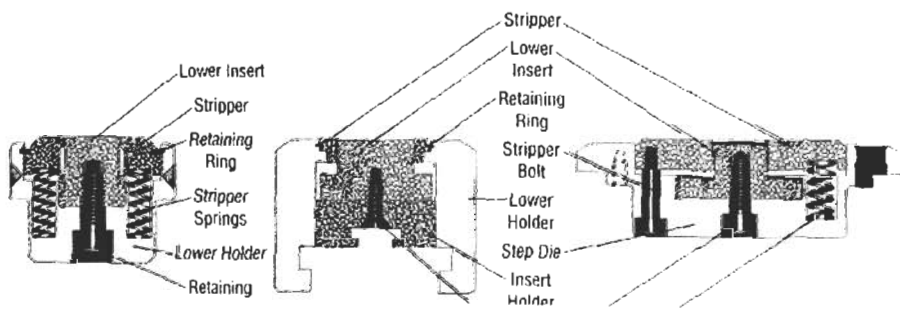
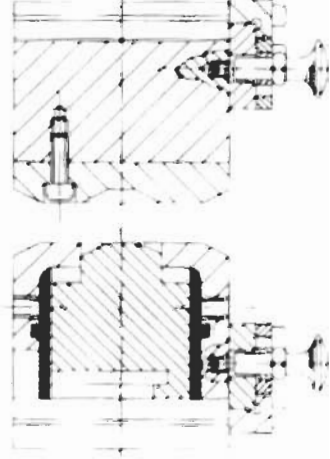

CLUSTER: Fully Guided Punch Assembly

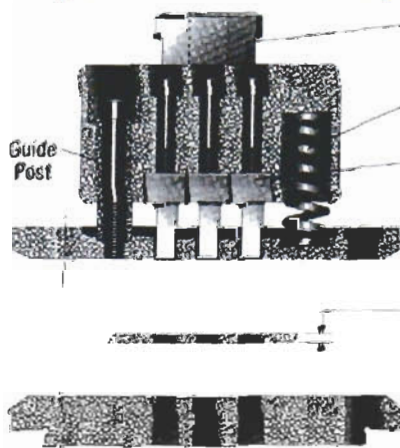

CLUSTER

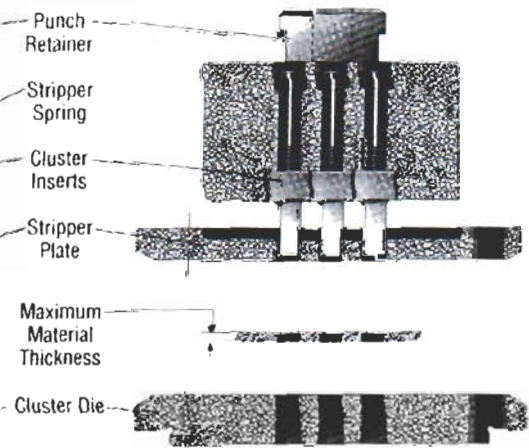

SPECIAL APPLICATION FORMING TOOLS

HIGHER PRODUCTIVITY THROUGH SUPERIOR ENGINEERING

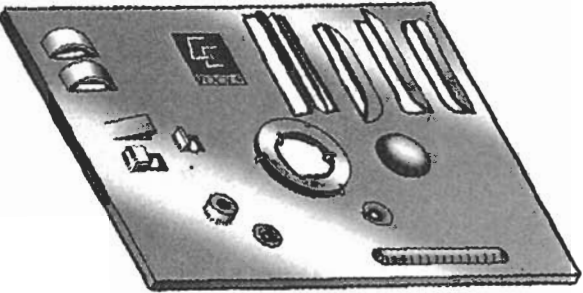

ELECTRICAL KNOCK OUTS

SINGLE Sp-60

Conduit	Actual Size	Conduit	Actual Size
1/2	.875	1 1/2	2.000
3/4	1.125	2"	2.500
1"	1.375	2 1/2	3.000
1 1/4	1.750	3"	3.625

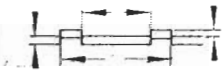

DOUBLE Sp-61

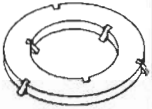

EMBOSES ROUND OR SHAPED

Form Down Sp74 Form Up Sp63

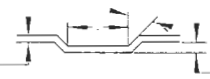

D >= 45° DIE w/No Stripper
Punch and Die Cat. Code
*FAT_PD-D72
Delivery 5-8 days

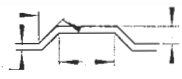

D >= 45° DIE w/No Stripper
Punch and Die Cat. Code
*FSA_PD-U63

D < 45° DIE w/Built in Stripper
Punch and Die Cat. Code
*FSA_PD-D72

D < 45° DIE w/Built in Stripper
*FSA_PD-U63
Delivery _ _ _ days

BRIDGE TOOL

SINGLE Sp-65 DOUBLE Sp-66

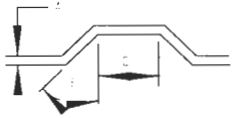
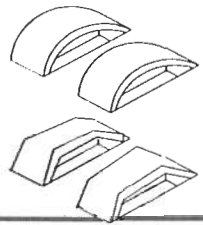

PROGRESSIVE STIFFENING RIB

Punch is made for a specific material

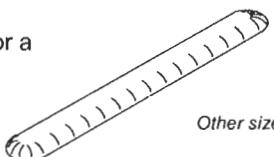

Other sizes available

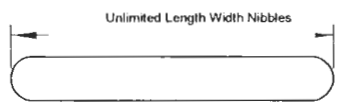

Unlimited Length Width Nibbles

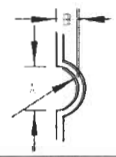

Standard Size	"A"	"B"	"R"
	3/8	3/16	3/16

THREAD FORM DOWN ONLY

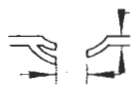
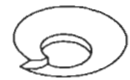

Replaceable Top Inserts *FIP81 Bottom *FID81

Ordering Notes:
Order by Screw & Thread size

Limitations Thread Pitch must be < than material thickness.

Contact C.E. Tooling Engineers with your specific needs, and they can discuss the feasibility and pricing for Thread

EXTRUSION

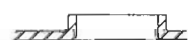
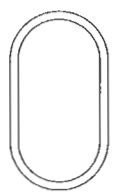

GROUND SYMBOL

Standard=1/2"Ø Longest horizontal line=3/8 length +\$50 for non standard

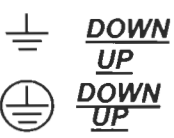

Fabricating Tools, Machinery, and Supplies

Specializing in tooling and machine parts for:

Amada, Behrens, Boschert, Chassis Maker, Di-Acro[®], Ehrt, Euromach, Finnpower, Haco, Murata Wiedemann, Nisshinbo, Omes, Pullmax, Rainer, Salvagnini, Simasv, Strippit[®], Trumpf, Raskin, Whitney and similar presses.

HIGHER PRODUCTIVITY THROUGH SUPERIOR ENGINEERING

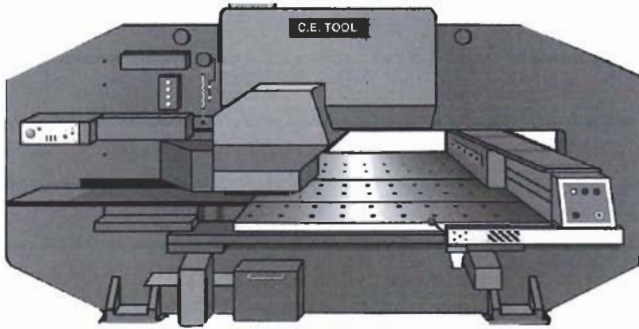

Further offering of Tooling for: Die-Sets, Press Brake, Iron Workers, Shears, C-Frame/Unitized Tooling, and Tube/Pipe Pierce & Bend



sales@cetooling.com

www.cetooling.com

Toll Free From: USA & Canada **800 634-6628** or 702 736-2598
Fax **800 848-3161** or 702 736-3038



HEAD QUARTERS
2560 W. Brooks Ave.
N. Las Vegas NV 89032

LOCAL SALES REPRESENTATIVE
DISTRIBUTORS

